

APPLICATIONS

- > Fast steering mirror
- > Point ahead mechanism
- > Line of sight stabilisation
- > Microscanning
- > Tracking
- > Pointing

KEY FEATURES

- > Compact size
- > Strain Gauges (SG) positioning sensor
- > Built-in SG conditioner
- > Large optical deflection angle > 1.2°
- > Low capacitance per axis
- > High control bandwidth
- > Short settling time
- > Operating temperature range
-55°C..+70°C

RELATED PRODUCTS

- > CCBu20
- > CCBu40

AVAILABLE OPTIONS

- > Glass mirror size under request
- > Specific control loop calibration

AVAILABLE INTERFACES

- > Specific mirror interface

ANNOTATIONS

Performances measured in labs environment. A misused can lead to temporary or definitive alterations of properties. Contact CEDRAT TECHNOLOGIES prior using actuators under non standard technical conditions.

(1) Full voltage range @ 1Hz.

(2) Peak to peak stroke in open & closed loop within the voltage range at ambient.

Piezo actuators are free of friction and their resolution is only limited by the SNR of the voltage amplifier and the measuring equipment resolution.

(3) In closed loop with SG sensor.

(4) Blocked-free: The actuator is fixed to a mechanical support assumed infinitely stiff.

(5) Loaded with an optional Glass mirror 25.4 mm diameter and 6 mm thickness (see picture).

(6) @-3dB and loaded with an optional Glass mirror 25.4 mm diameter and 6 mm thickness and controlled by CCBu40 controller.

(7) Unloaded, excluding wires.



PARAMETER	TYPICAL VALUE	UNIT
> Quasistatic performances ⁽¹⁾		
Max Angular stroke ⁽²⁾	> 10	mrad
Resolution ⁽³⁾	< 1	µrad
Linearity ⁽³⁾	< 0.2	%
> Dynamic performances		
Unloaded resonance frequency ⁽⁴⁾	> 1750	Hz
Loaded resonance frequency ⁽⁵⁾	> 1300	Hz
Control Bandwidth ⁽⁶⁾	> 350	Hz
10 mrad Settling time @ 5% ⁽⁶⁾	< 4	ms
1 mrad Settling time @ 5% ⁽⁶⁾	< 2	ms
> Driving		
Voltage range	-20...+150	V
Capacitance per axis	3	µF
> Dimensions & interfaces ⁽⁷⁾		
Height	<40	mm
Diameter	<65	mm
Mass	310	g

> **Mechanical interfaces** See icd

> **Optical interface** See icd

> **Electrical interfaces** See icd

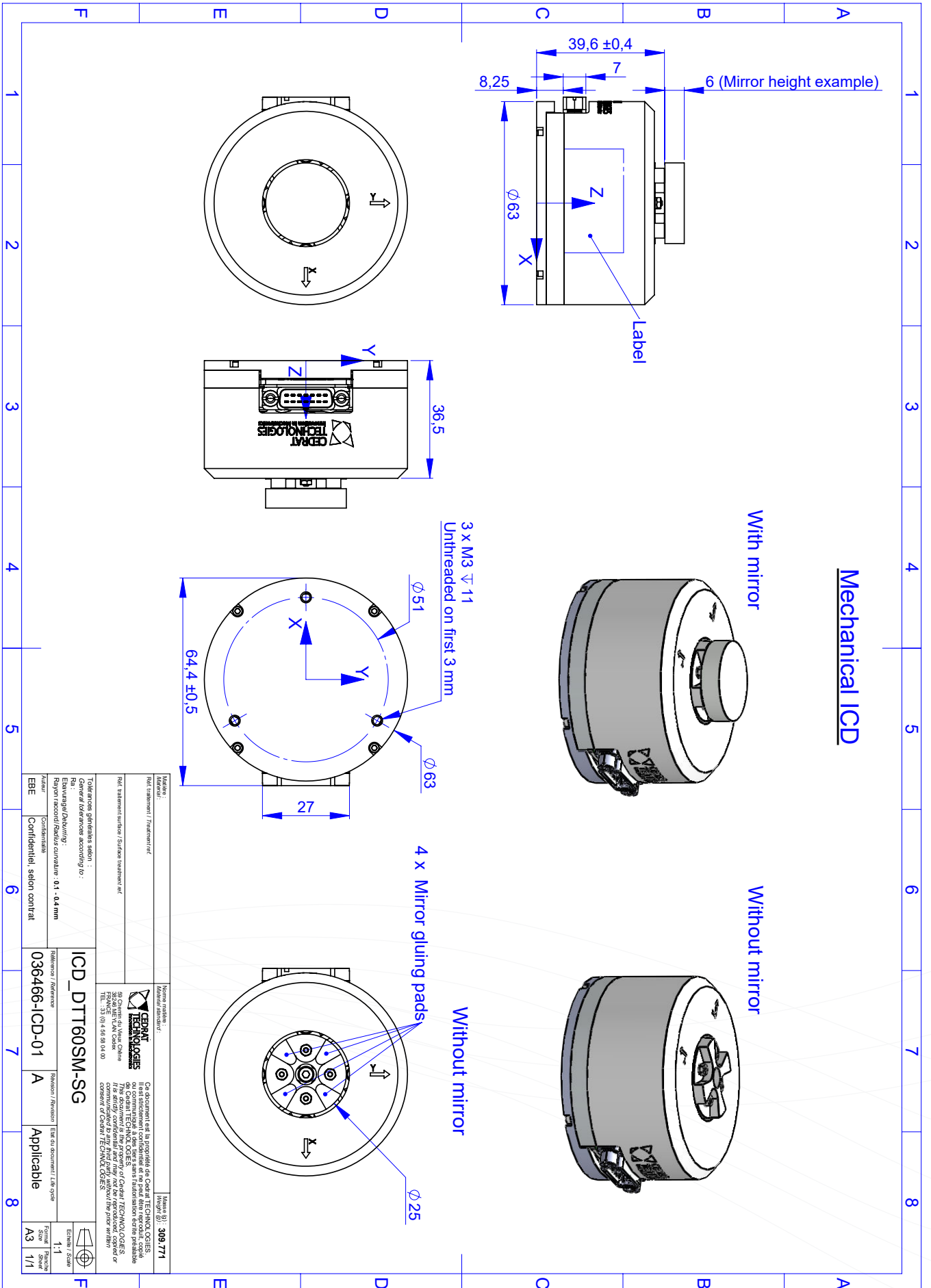

Mechanical ICD

With mirror

Without mirror

3 x M3 T 11
Unthreaded on first 3 mm

Without mirror

4 x Mirror gluing pads

Titre: Matériau: Réf. traitement / Treatment ref. Réf. traitement surface / Surface treatment ref. Tolérances géométriques selon : Ra : État de surface / Surface condition: 0.1 - 0.4 mm Général référence according to : Référence / Reference		Niveau qualité: Matériau standard: Ce document est la propriété de Cedrat TECHNOLOGIES. Il est strictement confidentiel et ne doit être reproduit, copié, communiqué ou diffusé sans l'autorisation écrite de Cedrat TECHNOLOGIES. It is strictly confidential and may not be reproduced, copied or communicated without the prior written consent of Cedrat TECHNOLOGIES. Niveau 01 Niveau 02 309.771	
Autre: Confidential, selon contrat Confidential		ICD_DTT60SM-SG 036466-ICD-01 A Applicable Forme / Shape Taille / Size État / State 1/1 1/1	