

## KEY FEATURES

- > Low voltage piezo ceramic
- > Optimal preload for high dynamics
- > Mechanical Amplification
- > Compact Size
- > High Resolution

## RELATED PRODUCTS

- > CTEC benchtop controllers
- > CTEC OEM controllers

## AVAILABLE OPTIONS

- > SG sensor
- > Vacuum compatibility
- > Ultra High Vacuum
- > Non magnetic shell

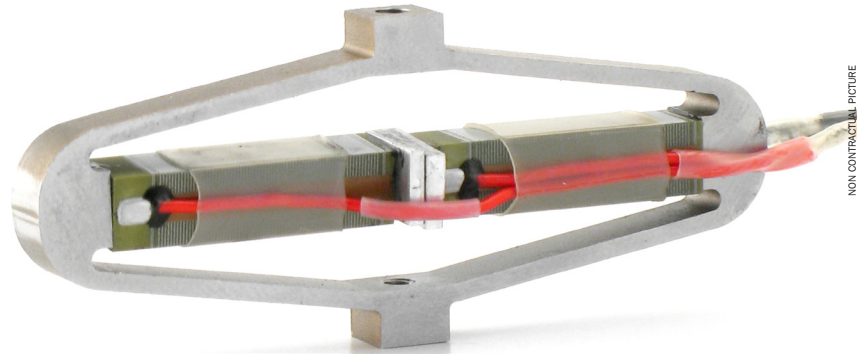

NON CONTRACTUAL PICTURE

PARAMETER	VALUE	UNIT
<b>&gt; Quasistatic performances</b>		
Nominal Stroke	190	µm
Min stroke	170	µm
Resolution <sup>(1)</sup>	10	nm
Blocked force	130	N
Stiffness	0.68	N/µm
<b>&gt; Dynamic performances</b>		
Resonance frequency (free-free) <sup>(2)</sup>	5 000	Hz
Resonance frequency (blocked-free) <sup>(3)</sup>	1 300	Hz
Force limit <sup>(4)</sup>	98	N
<b>&gt; Control &amp; driving</b>		
Voltage range	-20 ... 150	V
Capacitance <sup>(5)</sup>	2.2	µF
<b>&gt; Dimensions &amp; interfaces</b>		
Height	22	mm
Length	53	mm
Width incl wires	9	mm
Mass	17	g
<b>&gt; Standard mechanical interfaces</b>	See ICD	
<b>&gt; Electrical interface</b>	See ICD	

## ANNOTATIONS

(1) Quasistatic excitation. With standard LA75 range amplifier. SNR=85 dB computed as RMS output signal / RMS output Noise floor at [0;200 Hz]

(2) Free-free: The actuator mounts are free

(3) Blocked-free: The actuator is fixed to a mechanical support assumed infinitely stiff

(4) Maximum pulling or pushing external force, valid up to 90% of the blocked-free resonance frequency of the actuator

(5) Capacitance +/- 20%, at 1 V RMS, low frequency, without load

