

1 2 3 4 5 6 7 8

A

A

B

B

C

C

D

D

E

E

F

F

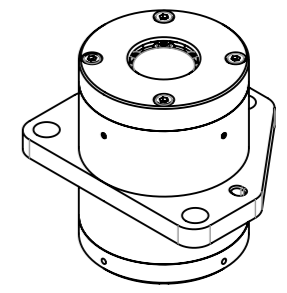
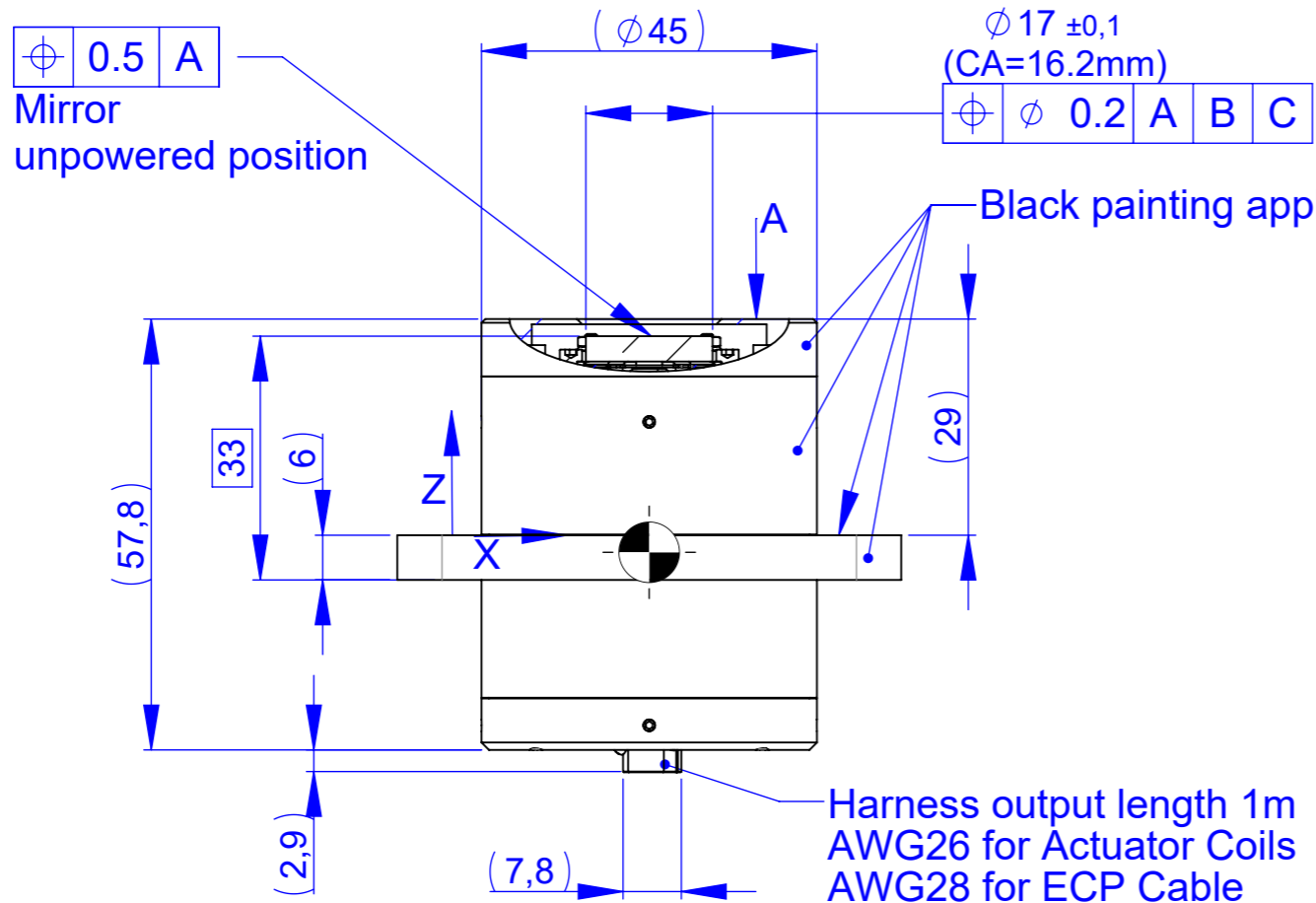
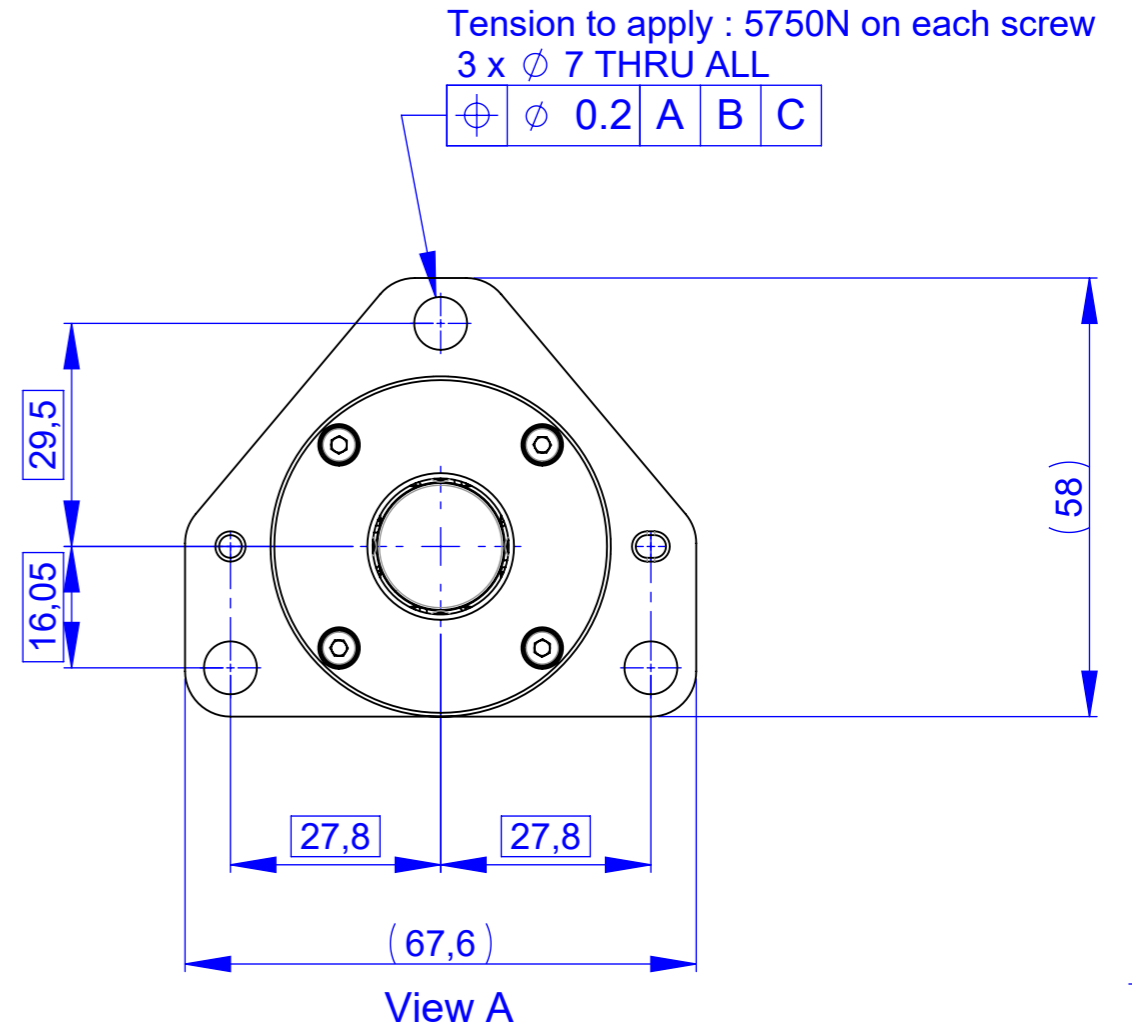
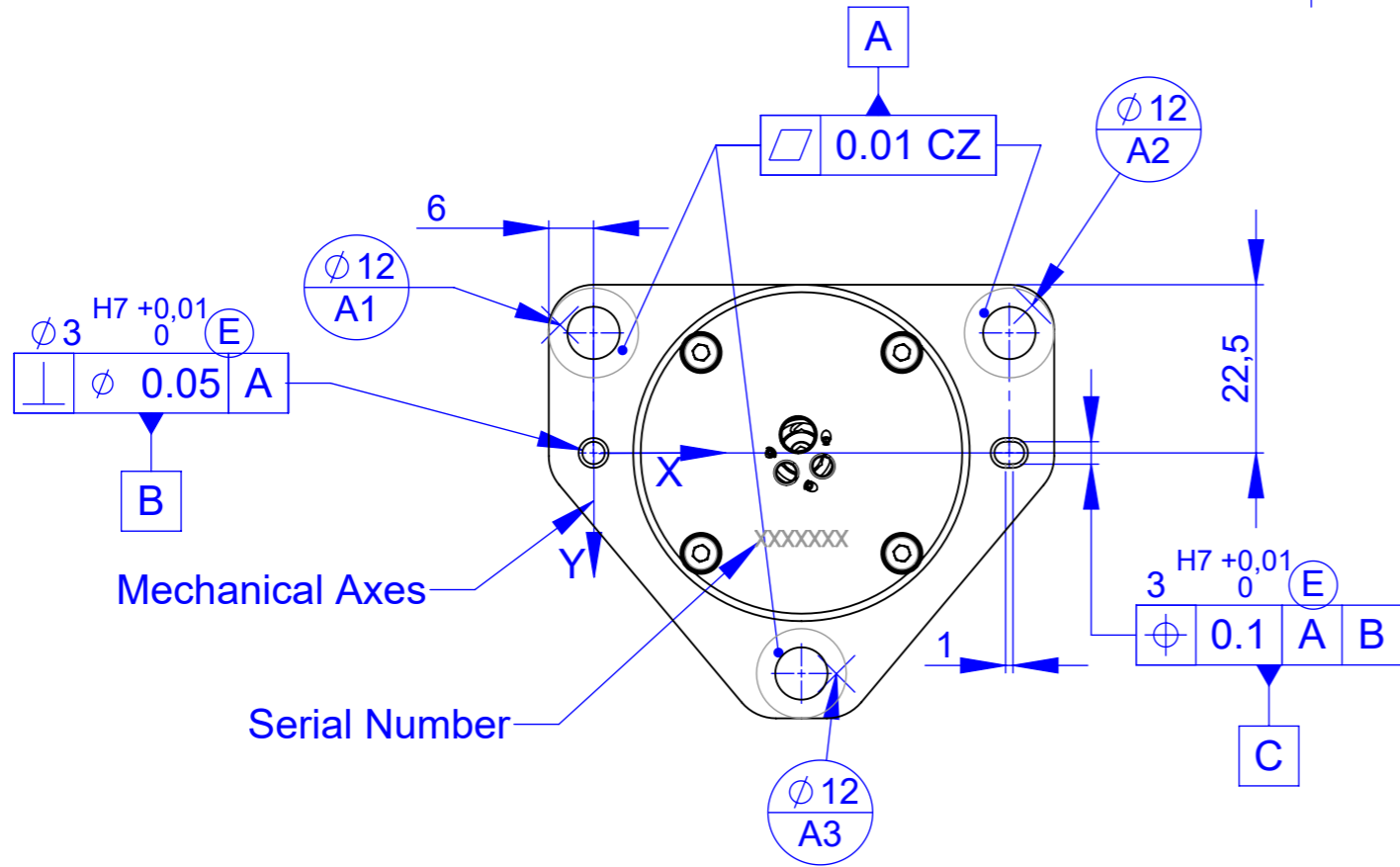

Rev.	Modifications
C	Screw tension updated. M4 grounding thread removed. Serial number position added
B	Definition of mechanical axes. Modification of I/F holes to M6. Addition of tolerances on pin system. Addition of details for wires output.
A	Creation

Matière : Material :		Masse approximative (g) : <b>370.00</b> Approximate mass (g) :	
Traitement / Treatment		<p>Ce document est la propriété de Cedrat TECHNOLOGIES. Il est strictement confidentiel et ne peut être reproduit, copié ou communiqué à des tiers sans l'autorisation écrite préalable de Cedrat TECHNOLOGIES. This document is the property of Cedrat TECHNOLOGIES. It is strictly confidential and may not be reproduced, copied or communicated to any third party without the prior written consent of Cedrat TECHNOLOGIES.</p>	
Auteur/Drawn		Référence / Reference	Révision / Revision
EBE	Confidentialité / Confidentiality Confidential, according to contract	047858-ICD-01	C
		Etat du document / Life cycle	Format / Planche Size / Sheet
		Applicable	A3 / 1/1

1 2 3 4 5 6 7 8