

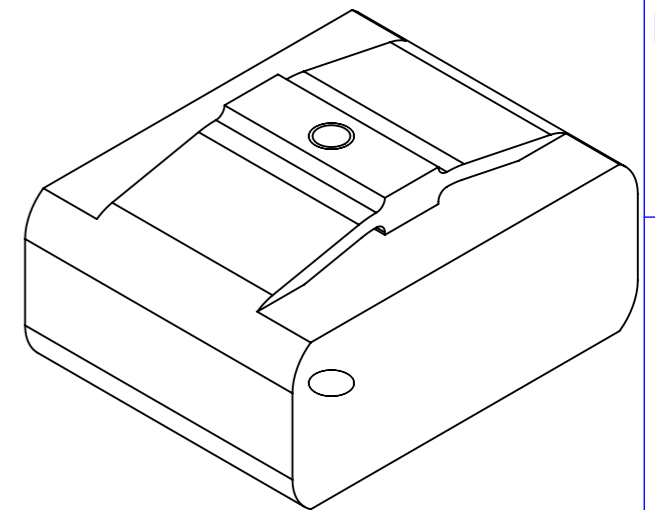

Wires outputs :  
2 twisted PTFE insulated AWG26  
wires 100mm long with Ø1mm  
banana plug

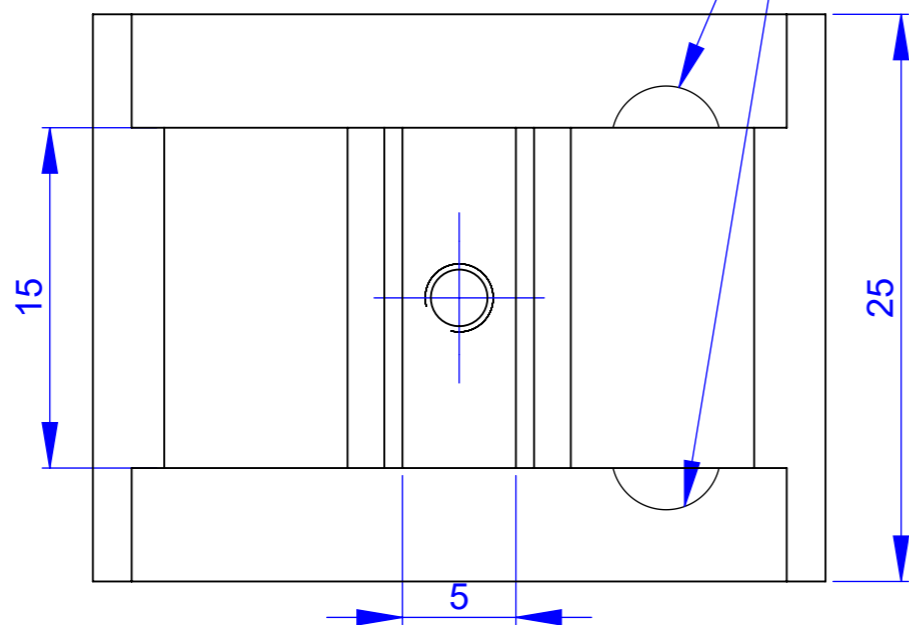
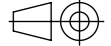

Matière : Material :		Norme matière : Material standard :		Masse (g) : Weight (g) :
Réf. traitement / Treatment ref.		 59 Chemin du Vieux Chêne 38246 MEYLAN Cedex FRANCE TEL : 33 (0) 4 56 58 04 00		Ce document est la propriété de Cedrat TECHNOLOGIES. Il est strictement confidentiel et ne peut être reproduit, copié ou communiqué à des tiers sans l'autorisation écrite préalable de Cedrat TECHNOLOGIES.  This document is the property of Cedrat TECHNOLOGIES. It is strictly confidential and may not be reproduced, copied or communicated to any third party without the prior written consent of Cedrat TECHNOLOGIES.
Réf. traitement surface / Surface treatment ref.				
Tolérances générales selon : General tolerances according to :		ICD APA60SL TH		 Echelle / Scale 3:1
Ra :				
Ebavurage / Deburring :		Référence / Reference		Format / Size A3
Rayon raccord / Radius curvature :		037957-ICD-01		
Auteur / Drawn		Révision / Revision		Planche / Sheet 1/1
QKR		F		
Confidentialité / Confidentiality		Etat du document / Life cycle		
Public		Applicable		