

CCBU20 COMPACT CONTROLLER BOARD

PRODUCT AND WARRANTY INFORMATION

Version: 1.5.1

Date: 09/03/2023

Author: Sylvain Duc

I. CAUTION: READ BEFORE OPENING

For safety purposes these instructions must be read before use of this product.

This product presents risks of severe injury or death due to burn hazards and electric shock.



Only qualified personnel should work on or around this equipment and only after becoming thoroughly familiar with all warnings, safety notices, and procedures contained herein.

The successful and safe operation of this equipment is dependent on proper handling, installation and operation.

A "qualified person" is one who is familiar with the installation, construction and operation of the equipment and the hazards involved. In addition, he/she has the following qualifications:

- is trained and authorized to energize, de-energize, clean, and ground equipment in accordance with established practices,
- is trained in the proper care and use of protective equipment in accordance with established safety practices,
- is trained in the soldering process and wiring of connectors,
- is familiar with the EMC and safety requirements.

To comply with the safety and EMC regulation, the user must install and configure the product correctly. Qualified person, who is familiar with the EMC and safety requirements, must install the product and is responsible for ensuring that the end product complies with the relevant laws in the country, where it is going to be used. Special care should be taken regarding electrical safety since the product is capable of providing high voltages.

II. INSPECTION UPON RECEIPT

This product has been inspected and shown to operate correctly at the time of shipment, as verified by the Factory Verification Form that accompanies the product.

Immediately upon receipt of the product, it should be inspected carefully for any signs of damage that may have occurred during shipment. If any damage is found, a claim should be filed with the carrier.

The package should also be inspected for completeness according to the enclosed packing list. If an order is incorrect or incomplete, contact your distributor.

III. INFORMATION ON DISPOSAL FOR USERS OF WASTE ELECTRICAL & ELECTRONIC EQUIPMENT (PRIVATE HOUSEHOLDS)

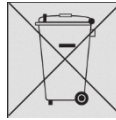

This symbol on the product(s) and / or accompanying documents means that used electrical and electronic products should not be mixed with general household waste. For proper treatment, recovery and recycling, please take this product(s) to designated collection points where it will be accepted free of charge.

Alternatively, in some countries you may be able to return your products to your local retailer upon purchase of an equivalent new product.

Disposing of this product correctly will help save valuable resources and prevent any potential negative effects on human health and the environment, which could otherwise arise from inappropriate waste handling.

Please contact your local authority for further details of your nearest designated collection point.

Penalties may be applicable for incorrect disposal of this waste, in accordance with you national legislation.

For business users in the European Union:

If you wish to discard electrical and electronic equipment, please contact your dealer or supplier for further information.

Information on Disposal in other Countries outside the European Union.

This symbol is only valid in the European Union. If you wish to discard this product please contact your local authorities or dealer and ask for the correct method of disposal.

IV. DISCLAIMER

All product, product specifications and data are subject to change without notice to improve reliability, function or design or otherwise.

Cedrat Technologies makes no warranty, representation or guarantee regarding the suitability of the products for any particular purpose or the continuing production of any product.

Except as expressly indicated in writing, Cedrat Technologies products are not designed for use in medical, life-saving, or life-sustaining applications or for any other application in which the failure of the Cedrat Technologies product could result in personal injury or death.

| | |
|---|-----------|
| I. CAUTION: READ BEFORE OPENING | 2 |
| II. INSPECTION UPON RECEIPT | 2 |
| III. INFORMATION ON DISPOSAL FOR USERS OF WASTE ELECTRICAL & ELECTRONIC EQUIPMENT (PRIVATE HOUSEHOLDS) | 3 |
| IV. DISCLAIMER | 3 |
| V. INTRODUCTION..... | 5 |
| V.1. OVERVIEW..... | 5 |
| V.2. CCBU20 CONFIGURATION..... | 6 |
| V.3. ARCHITECTURE | 7 |
| V.4. MODES OF OPERATION..... | 11 |
| VI. UNDERSTANDING THE FACTORY VERIFICATION SHEET | 11 |
| VII. MECHANICAL INSTALLATION..... | 13 |
| VIII. ELECTRICAL CONNECTIONS | 14 |
| VIII.1. INTERFACE WITH THE MECHANISM..... | 14 |
| VIII.2. INTERFACE WITH THE SUPERVISOR | 16 |
| VIII.3. EARTHING INTERFACE | 17 |
| IX. STARTING AND OPERATING THE CCBU20 | 18 |
| X. CONTROL..... | 19 |
| XI. COMMUNICATION INTERFACE | 20 |
| XI.1. SETTINGS..... | 20 |
| XI.2. STANDARD FORMAT | 21 |
| XI.3. HDPM45 GUI | 26 |
| XII. POWER SUPPLY, POWER CONSUMPTION, OUTPUT CURRENT CAPABILITY | 27 |
| XIII. THERMAL INTERFACE | 29 |
| XIV. TROUBLE SHOOTING FORM..... | 32 |
| XV. APPENDIX 1: MECHANICAL ICD..... | 33 |
| XVI. APPENDIX 2: SUPERVISOR INTERFACE BOARD ACCESSORY | 34 |

V. INTRODUCTION

V.1. OVERVIEW

The CCBu20 comprises all the required electronics to control in closed-loop a two-axis push-pull piezo-mechanism, i.e. power converters, conditioners, digital controller, and digital interface. The CCBu20 has external dimensions of 91x80x34mm. The CCBu20 is shown on the Figure V-1. The top of the packaging features two separate interface connectors (vertical):

- One for the mechanism or actuators.
- One for the supervisor (customer electronics).

Refer to chapter VIII.

The bottom of the packaging features the mechanical interfaces to attach the CCBu20. *Refer to chapter VI*

The bottom plate is also a thermal interface used to dissipate the heat of the CCBu20. The packaging also features side openings for air circulation in order to enhance the heat dissipation. *Refer to chapter XIII*

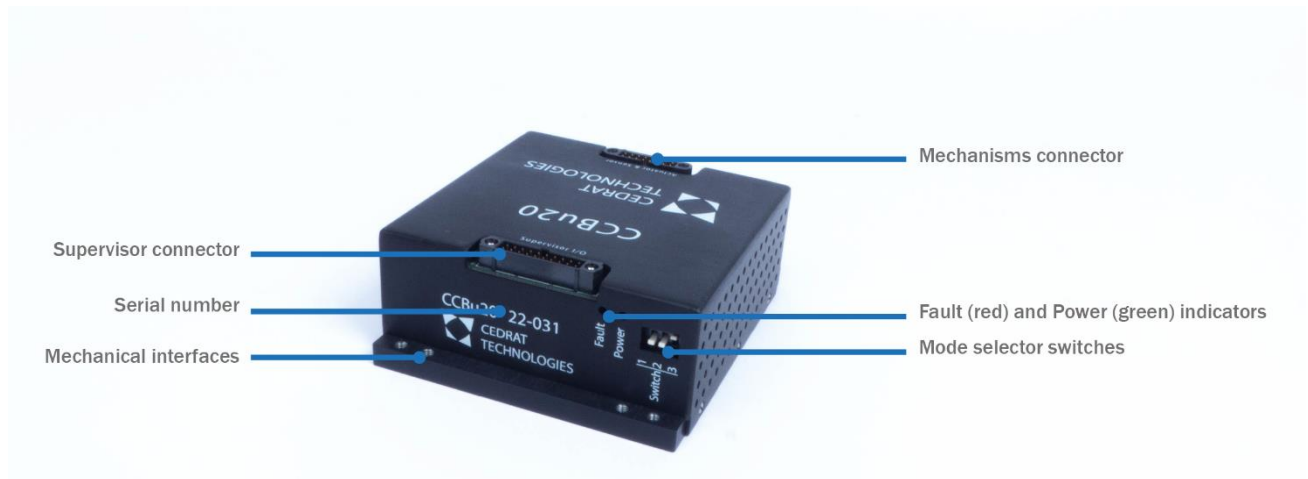

Figure V-1: View of the CCBu20 with standard vertical connectors.

The CCBu20 only requires a single DC power supply between +24Vdc and +28Vdc to operate. Two status LEDs indicate the condition of the system. The green LED “Power” indicates that the CCBu20 is powered on, and the red LED “Fault” indicates if a fault condition has been detected or if the CCBu20 is disabled. The board integrates overtemperature detection, overload detection, and mechanism disconnected detection.

The functionality of the board can be set in different modes with switches. The choice can be made between analog and digital commands, and it is possible to select between two different speeds for the digital communication.

Digital communication with the board comes in a full-duplex serial link with RS422 signaling to reach high speeds. The digital link serves to set the parameters of the control loop, and can also serve to send the commands to the board and get feedback. *Refer to chapter XI.*

V.2. CCBU20 CONFIGURATION

FACTORY CONFIGURATION

On customer request and depending on the associated mechanism, the CCBu20 could have the following configuration:

- Sensor conditioning

Two standard configurations exist: the CCBu20 is equipped with a sensor conditioning or not. When the associated mechanism is already equipped with a sensor conditioning (a strain gauge or any other sensor with integrated conditioning stage providing a $\pm 10V$ signal).

This information is given in the mechanism user manual.

- Closed loop order

In default configuration, the gain between the sensor feedback and the analog command is 1. Which means that if the sensor feedback is between -4V and +4V for the full mechanism stroke, the user must send an analog order between -4V and +4V to reach the full stroke.

Some other configurations are available. The gain could be higher to maximise the input voltage resolution measurement (the maximum is for an analog signal between -10V and +10V). An offset could be added (for example to have an analog input voltage only positive).

This information is given in the mechanism Factory Verification Sheet in the 'displacement VS input voltage in close loop' test.

USER CONFIGURABLE CONFIGURATION

- Control parameters

In default configuration the control parameters are the following: $P=0.05$, $I=200$, $D=0$. Output filter is a second order lowpass filter with cutoff frequency of 200Hz.

When the CCBu20 is associated with a mechanism, these parameters could be tuned to reach the mechanism performances. This information is given in the the mechanism Factory Verification Sheet.

- Configuration switches

3 mode selections switches are present on the CCB. The position of the switches must be set before the CCB power up.

- Switch 1 (reserved)

This switch must always remain down

- Switch 2

When this switch is up, it forces the CCB on analog command. The user must send the movement order on the AiX and AiY input.

When this switch is down (default configuration) the user can select, through the RS communication, the order mode (analog or digital). On delivery the analog mode is set.

- Switch 3

When this switch is up (default configuration) the RS communication is forced to 57600 bauds. When this switch is down, the RS baud rate is set to the user configurable one. On delivery, this speed is set to 937.5kbps.

For more information refer to chapter XI/ Communication interface.

V.3. ARCHITECTURE

The architecture of the CCBu20 is represented schematically on the Figure V-2 or Figure V-3 depending on the selected sensor. On the figures, the commands for adjusting the configuration are identified with " marks. The details of the commands are given in Section XI.2. The CCBu20 has two fully independent control channels, thus it is able to control a 2-axis push-pull mechanism, or 2 single axis piezo-mechanisms. The structure of the channels is identical, as can be noticed on the figures.

According to the purchased configuration, the CCBu20 can feature two SG sensors conditioners (one per channel) which provide a voltage output between $\pm 10V$ corresponding to the position measurement. Alternatively, the CCBu20 exists in optional hardware configuration without SG conditioning. In that case, the $\pm 10V$ sensor signals are provided directly on the mechanism connector, and no conditioning is applied. The sensor measurements are sampled by the controllers to perform closed-loop control. Those measurements can be read using the analog outputs "SX" and "SY", or through the digital link.

For driving the piezo-actuators, the CCBu20 features 3 high voltage power amplifiers. The first power amplifier provides the +130V in case a push-pull mechanism is controlled, and its output voltage is fixed. The 2 other amplifiers are controllable, and each is associated to a control channel. Those amplifiers have an approximate gain of 20V/V. They take a command voltage between [-1V ; +7.5V], and output a voltage to the piezo-actuators in the range of [-20V ; +150V] approximately.

The user has the possibility to set limitations on the commands before they are applied to the amplifiers. This can be very convenient to protect the system when tuning the closed-loop control, in case some instability would occur. Once the closed-loop is properly tuned and robust, the user can set again the limitations to the maximum values [-20V ; +150V] to achieve full stroke.

The internal digital preamplifier is set to translate from customized range order to standard range order [-1V; +7.5V]

There is one digital controller per channel of the CCBu20, and they are independently configurable. The details on the closed-loop controllers are given in the Section X. The user can configure the board to operate with analog $\pm 10V$ commands from the "AIX" and "AIY" inputs, or to operate from the digital commands sent through the digital communication. The user can also select between open-loop and closed-loop operation:

- In open-loop operation, the commands are fed to a preamplifier if the input range is customized and then the power amplifiers.
- In closed-loop operation, the commands are fed to the closed-loop controllers. The closed-loop controller outputs are controlling the power amplifier inputs. The role of the closed-loop controller is to make sure that the sensor signal voltage equal to the command voltage. This means that the command gain is equal to the sensor gain. The user should provide commands that are in the range of the sensor output displayed in the HDPM which is the analog sensor output amplified with the "sensor ratio" digital gain. If the command is outside this range, the controller will simply saturate.

Optionally, the mechanism can integrate a PT1000 temperature sensor, as well as a DS2431 1-wire memory. Those functions are optional and thus not represented on the figures. The DS2431 memory is an option that can be used for storage of calibration data upon specific customer request, this option is managed only by Cedrat Technologies.

For the optional temperature sensor, this can be managed by Cedrat Technologies as an option directly integrated on the mechanism or actuator. If the customer is responsible for the wiring of the mechanism or actuators, he has the possibility to integrate the sensor himself. The sensor should be of type PT1000, and it should be connected between the "T°C" and "AGND" pins of the **mechanism connector**. The temperature

signal can then be read as a voltage on the “T°C” analog output of the supervisor connector. The CCBu20 integrates a conditioner that provides a constant 1.613mA current to the PT1000 probe. Based on the voltage measurement on the “T°C” output, the temperature in °C is computed as follows:

$$\text{Temperature [}^{\circ}\text{C]} = (\text{“T}^{\circ}\text{C” output [V]} - 1.613) \times 161$$

Notes:

- **When monitoring the sensor signals on the “SX” and “SY” outputs, it is recommended to use a low-pass filter to remove switching noise that can appear on those lines. This is also recommended for temperature reading (if used) on the “T°C” output.**

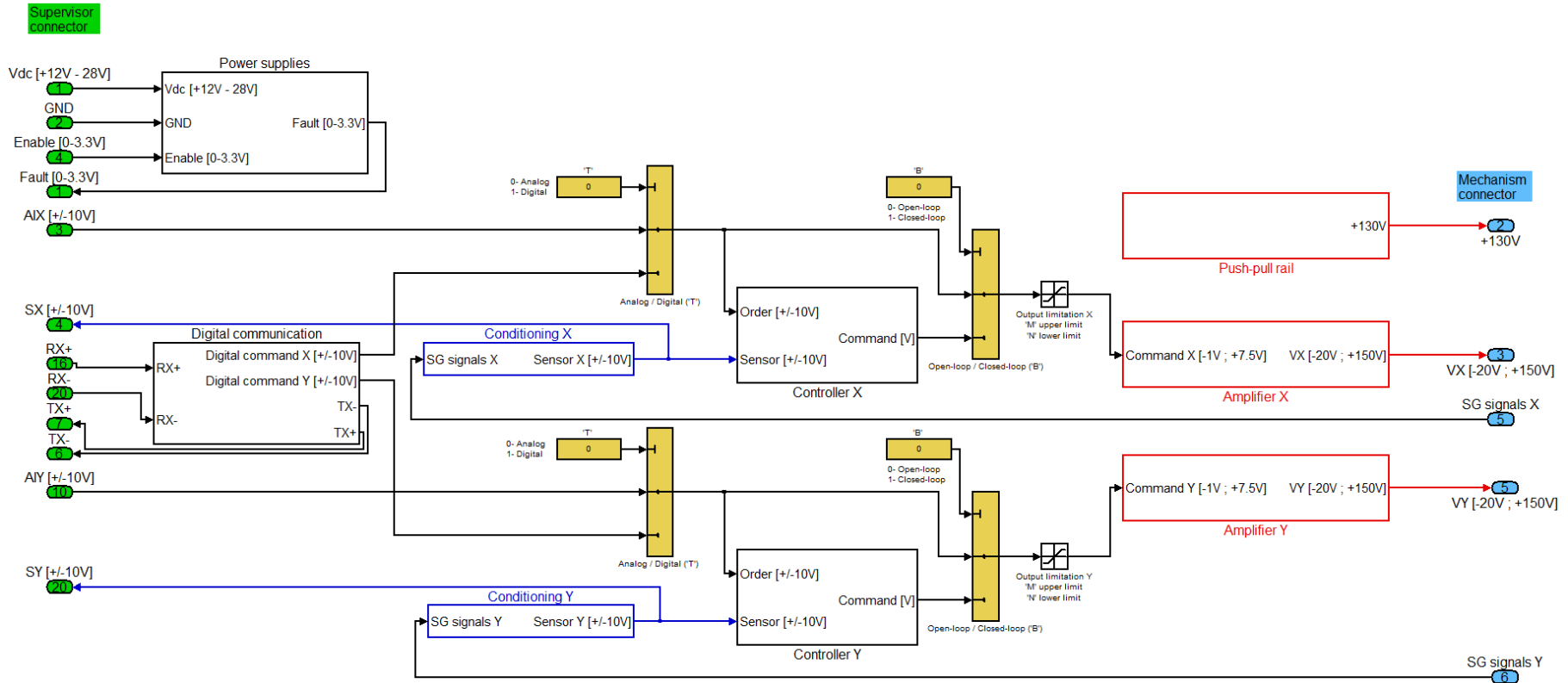

Figure V-2: Architecture of the CCBu20 with integrated SG conditioner.

Important warning: The numbering on the Figure V-2 and Figure V-3 does not correspond to the pinouts of the connectors. For connectors pinout, please refer to chapter VIII.

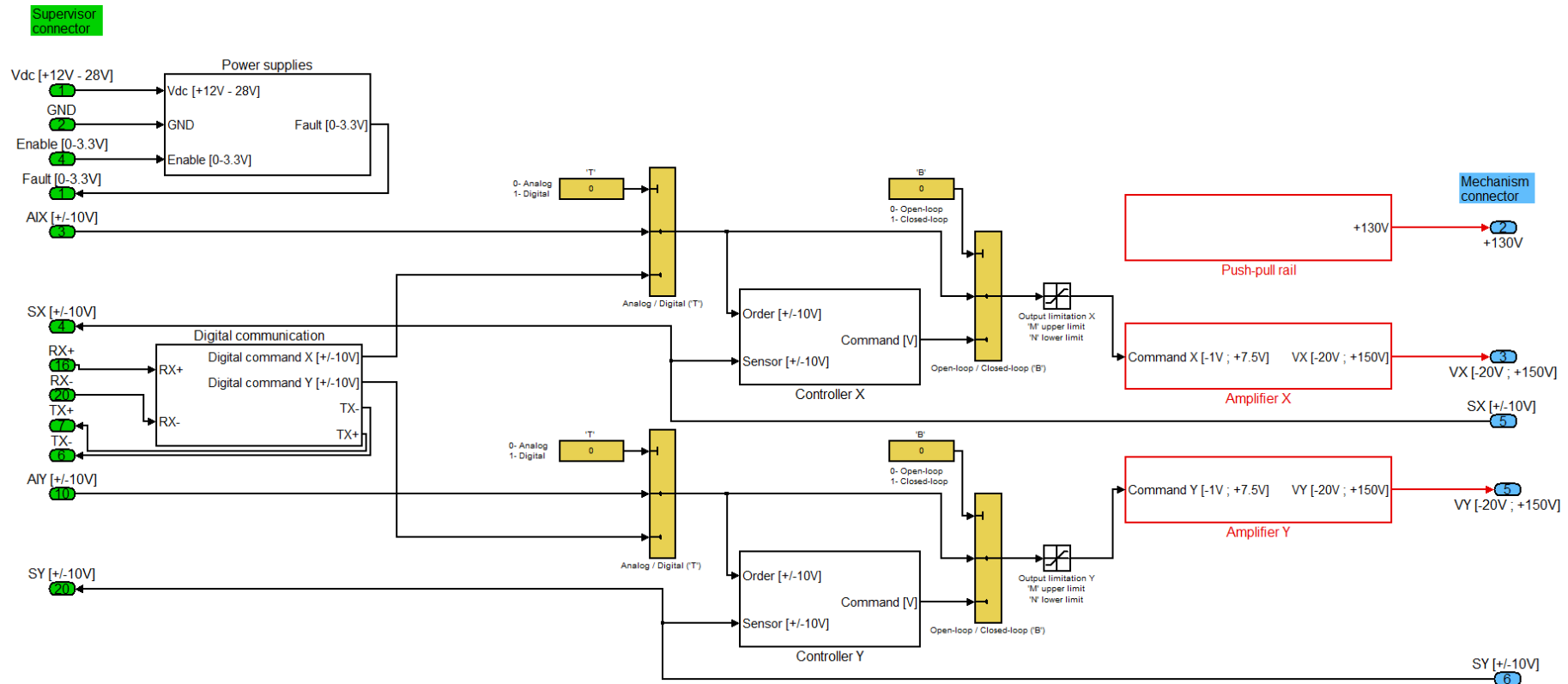

Figure V-3: Architecture of the CCBu20 with external sensor option.

Important warning: The numbering on the Figure V-2 and Figure V-3 does not correspond to the pinouts of the connectors. For connectors pinout, please refer to chapter VIII.

V.4. MODES OF OPERATION

The CCBu20 can be set by customer in different modes depending on the user requirements.

ANALOG AND DIGITAL COMMAND

The CCBu20 can receive analog or digital commands. The supervisor connector has two $\pm 10V$ analog inputs "AIX" and "AIY", which should be used to apply the analog commands. In digital mode, the commands are sent through the serial link. When the switch N°2 is set in up position, the board uses only the analog inputs. When this switch is set in down position, the type of command is selected in software between analog and digital commands.

OPEN AND CLOSE LOOP OPERATION

The CCBu20 can operate in closed-loop or in open-loop. In open-loop, the user commands are directly sent to the power drives. In closed-loop, the CCBu20 controls the system position based on the sensor feedback and user commands. The selection between closed-loop and open-loop is done in software.

Note: The position of the switches are only verified on power-up. If a switch is toggled during operation, the CCBu20 will not change its configuration.

VI. UNDERSTANDING THE FACTORY VERIFICATION SHEET

Each CCBu20 is delivered with a Factory Verification Sheet (FVS). This FVS is the proof that the CCB has successfully passed CTEC acceptance tests.

The table VI-1 shows some useful information about the CCB like the CCB serial number (also mark on the top cover).

| | | | |
|--------------|--------|-------------------|------------|
| OPERATOR | DQU | OPERATION DATE | 24/02/2021 |
| PRODUCT NAME | CCBu20 | PART NUMBER P/N | 037155C |
| OPTION | | SERIAL NUMBER S/N | 20006 |
| CCBu20 FW | 1,08 | LABVIEW FW | 1.0 |

Table VI-1 : Useful information about the CCB

The first test (Rising time / falling time) verifies for each output the peak current capability of the CCB which is about 0.2A. these tests are done by measuring the voltage rising time on a capacitive load with a full amplitude square order.

A table shows the measured values and the acceptance criteria, under the table the measured curved are drawn.

| | VALUE OR STATUS | UNIT | ACCEPTANCE CRITERIA | ACCURACY |
|------------------------------|-----------------|--------------|---------------------|----------|
| Rise time (10-90%) X channel | 3,400 | MILLISECONDS | $2,9 < Tr < 3,8$ | 0,1 |
| Fall time (90-10%) X channel | 3,000 | MILLISECONDS | $2,4 < Tf < 3,0$ | 0,1 |
| Rise time (10-90%) Y channel | 3,400 | MILLISECONDS | $2,9 < Tr < 3,8$ | 0,1 |
| Fall time (90-10%) Y channel | 3,000 | MILLISECONDS | $2,4 < Tf < 3,0$ | 0,1 |
| Comment | | | | |

Rising/Falling time VX

Rising/Falling time VY

Figure VI-1: Example of rising and falling time measurement

The second test (Linearity) compares in open loop the output voltage vs the input order. The amplifier gains are calculated.

| | VALUE OR STATUS | UNIT | ACCEPTANCE CRITERIA | ACCURACY |
|-----------------------|-----------------|------|---------------------|----------|
| Gain X channel(VS/VE) | 19,995 | NA | $20 \pm 0,05$ | 0,01 |
| Gain Y channel(VS/VE) | 19,999 | NA | $20 \pm 0,05$ | 0,01 |
| Comment | | | | |

Linéarité VX

Linéarité VY

Figure VI-2: Example of linearity measurement

VII. MECHANICAL INSTALLATION

The bottom of the packaging features 8xM3 threaded holes to allow different mounting configurations:

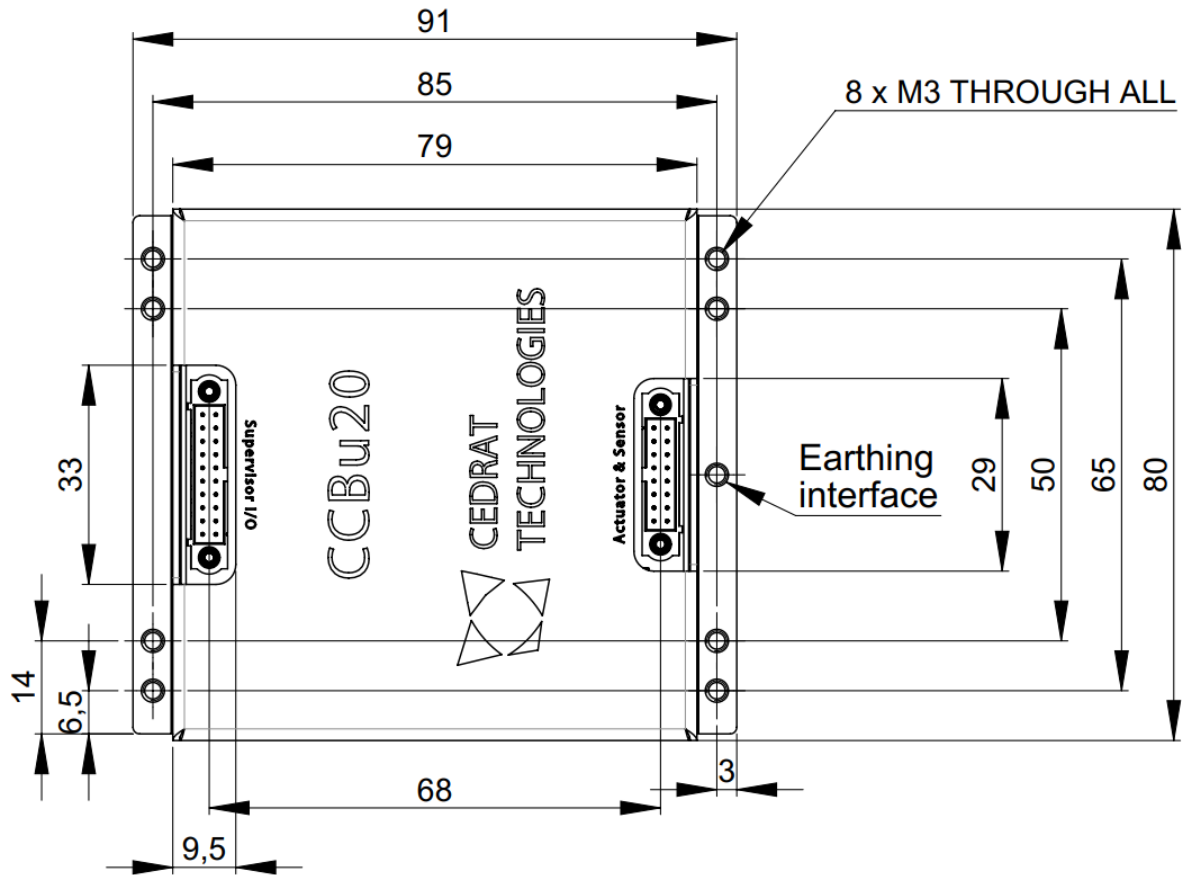

Figure VII-1: Threaded holes for installation.

Detailed mechanical ICD can be found in Annex. The bottom surface of the CCBu20 serves as a heatsink. Please check Section XIII for heatsinking requirements.

VIII. ELECTRICAL CONNECTIONS

IMPORTANT WARNINGS: ELECTRICAL HAZARD



For protection against electric shock, connectors must be isolated from the power supply while being assembled or disassembled.

Never perform electrical connections when the CCBu20 is powered-on. The CCBu20 provides high voltage outputs to the piezo-actuators (>100V), and there is a risk of electrical shock. If the board has been powered-on before, wait at least 1min after power-off before working on the electrical connections.

Each time the connectors are used, it should previously be inspected for external defects (particularly in the insulation). If there are any doubts as to its safety, a specialist must be consulted or the connector must be replaced.

VIII.1. INTERFACE WITH THE MECHANISM

For the interface of the CCBu20 with the mechanism, the connector is a HARWIN M80-5101642 (vertical) or M80-5401642 (horizontal) on the CCBu20.

It is a through hole, male 16pins connector (Figure VIII-1). To mate with this connector, the user should use M80-4611642 or M80-4811642.

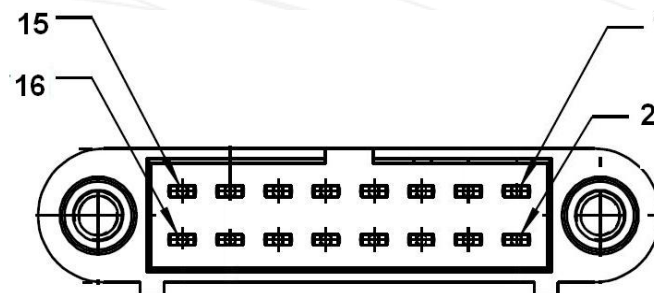

Figure VIII-1: *Front view of the mechanism connector M80-5101642 on the CCBu20.*

The definition of the signals on the connector is given on the Table VIII-1.

| Pin N° | Signal | Description | Comment |
|--------|--------------------------------|--|---|
| 1 | VREF | +5V voltage reference for supplying the two SG bridges | This voltage supplies two full SG bridges of 350Ω. Max current is 30mA. |
| 2 | AGND | Analog ground, return for the low power signals | This is the reference for all the low power signals, both sensors and memory |
| 3 | SGX+ | Positive middle node for the X axis SG bridge | Voltage increases when the displacement on the X axis increases. |
| | <u>SX / SX+</u> ⁽¹⁾ | X axis external sensor | +/-10V external sensor option. Single ended or positive differential input |
| 4 | SGX- | Negative middle node for the X axis SG bridge | Voltage decreases when the displacement on the X axis increases. |
| | <u>SX- / NC</u> ⁽¹⁾ | Negative X axis external sensor | +/-10V external sensor option Not used for single ended input Negative differential input |
| 5 | SGY+ | Positive middle node for the Y axis SG bridge | Voltage increases when the displacement on the Y axis increases. |
| | <u>SY / SY+</u> ⁽¹⁾ | Y axis external sensor | +/-10V external sensor option. Single ended or positive differential input |
| 6 | SGY- | Negative middle node for the Y axis SG bridge | Voltage decreases when the displacement on the Y axis increases. |
| | <u>SY- / NC</u> ⁽¹⁾ | Negative Y axis external sensor | +/-10V external sensor option Not used for single ended input Negative differential input |
| 7 | 1WIRE | 1-wire bus for EEPROM memory | Optional: can be connected to a DS2431 EEPROM located on the mechanism. |
| 8 | PT1000 | Temperature signal from the integrated temperature probe | Optional: can be connected to a PT1000 temperature probe located on the mechanism. |
| 9 | +15 | +11V power supply | Max current is 20mA. |
| 10 | -15 | -11V power supply | Max current is 20mA. |
| 11 | PGND | Power ground | Power signal, current return from the actuators |
| 12 | PLUG | Mechanism detection | The mechanism shall connect this pin to AGND or PGND, to be detected by the CCBu20 |
| 13 | +130 | +130V rail | For the push-pull configuration |
| 14 | CHASSIS GND | Electrical ground connection | For shielding purpose |
| 15 | VPIEZOX | X axis voltage output | This voltage is varying, and controls the displacement on the X axis |
| 16 | VPIEZOY | Y axis voltage output | This voltage is varying, and controls the displacement on the Y axis |

Table VIII-1 : Connection with the mechanism ⁽²⁾

¹ External sensor configuration. Available on request, please inform Cedrat Technologies when ordering.

The CCBu20 offers the ability to close the loop with a +/-10V single ended or differential sensor input option. This is useful when an external sensor conditioner is employed or when the mechanism includes a SG sensor conditioner. +11V and -11V power supplies are available to power the conditioner.

² **Important Note: Mechanism connector of CCBu20 with serial number lower than 20-xxxx follow a different pin out.** Please contact Cedrat Technologies to get the correct user manual. Irreversible damage may occur if these instructions are not followed on those specific versions. In case of doubt contact Cedrat Technologies.

VIII.2. INTERFACE WITH THE SUPERVISOR

For the interface with the supervisor, a HARWIN M80-5102042 (vertical) or M80-5402042 (horizontal) is selected on the CCBu20. It is a through hole, male 20pins connector (Figure VIII-2). To mate with this connector, the user should use M80-4612042 or M80-4812042.

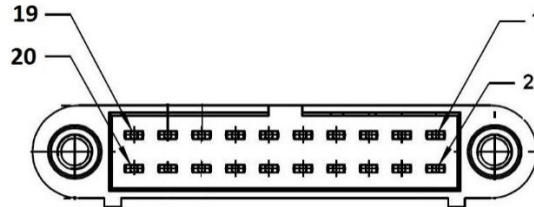

Figure VIII-2: *Front view of the supervisor connector M80-5102042 on the CCBu20.*

The definition of the signals on the connector is given on the Table VIII-1:

| Pin N° | Signal | Description | Comment |
|--------|--------|-------------------------------------|--|
| 1 | SY | Analog sensor output for Y axis | ±10V output. Referenced to AGND |
| 2 | SX | Analog sensor output for X axis | ±10V output. Referenced to AGND |
| 3 | AIY | Analog order input for Y axis | ±10V input. Referenced to AGND |
| 4 | AIX | Analog order input for X axis | ±10V input. Referenced to AGND |
| 5 | T°C | Mechanism analog temperature output | 0-3.3V output. Only valid if PT1000 is used on the mechanism. Referenced to AGND |
| 6 | AGND | Analog ground | Reference for analog I/Os. |
| 7 | Fault | Digital fault output | 0-3.3V output. Referenced to GND |
| 8 | Enable | Digital enable input | 0-3.3V input. Referenced to GND |
| 9 | CTS- | Negative Clear To Send signal | Connect to supervisor RTS- |
| 10 | CTS+ | Positive Clear To Send signal | Connect to supervisor RTS+ |
| 11 | RTS- | Negative Request To Send signal | Connect to supervisor CTS- |
| 12 | RTS+ | Positive Request To Send signal | Connect to supervisor CTS+ |
| 13 | TX- | Negative Transmit RS422 signal | Digital output. Connect to supervisor RX- |
| 14 | TX+ | Positive Transmit RS422 signal | Digital output. Connect to supervisor RX+ |
| 15 | RX- | Negative Receive RS422 signal | Digital input. Connect to supervisor TX- |
| 16 | RX+ | Positive Receive RS422 signal | Digital input. Connect to supervisor TX+ |
| 17-18 | GND | CCBu20 ground | Reference of the CCBu20. Connected to mechanical ground. |
| 19 -20 | Vdc | CCBu20 power supply | +24V - +28V range, with maximum 1A continuous capability. Referenced to GND. |

Table VIII-1: *Connection with the supervisor. ⁽³⁾*

Warning: The analog output signals “SX” and “SY” have a 1kΩ output impedance, and “T°C” have a 20kΩ output impedance, for protection purpose. If used, they should be monitored with high input impedance device, or this output impedance should be taken into account.

³ **Important Note:** Supervisor connector of CCBu20 with serial number lower than 20-xxxx follow a different pin out. Please contact Cedrat Technologies to get the correct user manual. Irreversible damage may occur if these instructions are not followed on those specific versions. In case of doubt contact Cedrat Technologies.

VIII.3. EARTHING INTERFACE

The CCBu20 must be connected to ground / earth using the below interface:

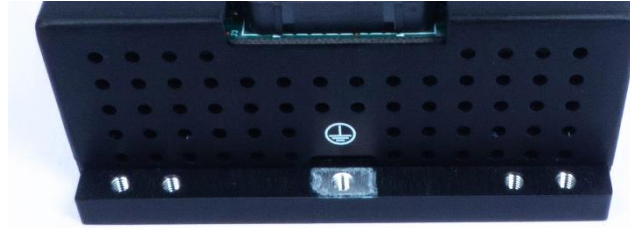

Figure VIII-3: Earthing interface

This is an M3 interface, for a ring cable lug.

This is not a functional earthing, so the product will still work without this connection.

IX. STARTING AND OPERATING THE CCBu20

Warnings:

- The supply voltage should never exceed +32Vdc. Exceeding +32Vdc will lead to permanent damage of the CCBu20.
- The wiring and mechanical installation should be performed before powering up the CCBu20.
- Switches should be set to the desired configuration before power-up.

First, the CCBu20 should be powered on by a nominal supplying a voltage between +24Vdc and +28Vdc.

Note: Maximum peak output power may not be available if the power supply peak current is below 5A peak.

After power-up, the green “Power” indicator should light.

The CCBu20 startup is controlled with the “Enable” digital input on the supervisor connector. When the “Enable” signal is grounded (0V), the CCBu20 remains in standby, and power converters are not activated. In this mode, no motion can be applied to the actuators. In standby, the “Fault” LED and “Fault” signal are set to indicate that the system cannot operate. In this mode, the power consumption is reduced. When the “Enable” signal is high impedance (or tied to a +3.3V), the CCBu20 launches the startup procedure. If the startup is successful (no fault detected), the CCBu20 starts operating normally and applies the user commands. The CCBu20 can be deactivated at any time by bringing the “Enable” signal low.

The board is capable to detect 3 fault conditions:

- Overtemperature
- Overload
- Missing connector (no mechanism is connected)

Upon startup of the board, the conditions are tested. If a fault is detected the board will go to fault mode, and the red LED “Fault” will light to indicate the fault condition. In addition, the “Fault” output will be set to the high level (+3.3V). In fault mode, the power converters are deactivated, and the board will not function properly. Fault mode is equivalent to standby mode. To regain functionality after a fault, the user has to reset the board:

- The “Enable” input should be asserted high (+3.3V) and then low (0V) again to try to restart the board. If the startup procedure is successful, the board will operate properly.

Overtemperature condition is constantly monitored during the system operation. If the overtemperature condition appears during the normal system operation, the board will go to the fault mode. The same principle applies for the missing connector detection.

Note: The communication becomes active as soon as the green “Power” indicator lights. The communication remains active even in Standby of Fault condition.

X. CONTROL

The role of the closed-loop control is to make sure that the sensor feedback is equal to the command. This means that the system gain in closed-loop corresponds to the SG sensor gain, provided in the factory verification sheet.

Warnings:

- **When tuning the control parameters, the user should avoid instability conditions. In case of instability, there is a risk of damage to the actuators and CCBu20. Please refer to the application note “Position Control of Piezo Actuators” for hints on how to tune a controller for piezo-actuator. You can download this application note here: <http://www.cedrat-technologies.com/en/products/users-manual.html>**
- **The sensor feedback has to be in phase with the piezo voltage. This can be checked by operating the CCBu20 in open-loop, the sensor should be in phase with the command. If this is not the case (in particular with the external sensor option), there is the possibility to adjust and invert the sensor feedback gain in software if needed. See digital command ‘G’ in the Section 0.**

The CCBu20 performs a digital control law basically consisting in a PID controller with a selectable and tunable output filter. Each of the two channels has its own independent controller, which can be tuned independently. The CCBu20 refresh rate is of 20kSps.

The controller is presented schematically on the Figure X-1. The user can modify all control parameters to optimize the performance. The commands for adjusting the parameters are identified with ‘ ’ marks. The details of the commands to adjust the control parameters are given in Section 0.

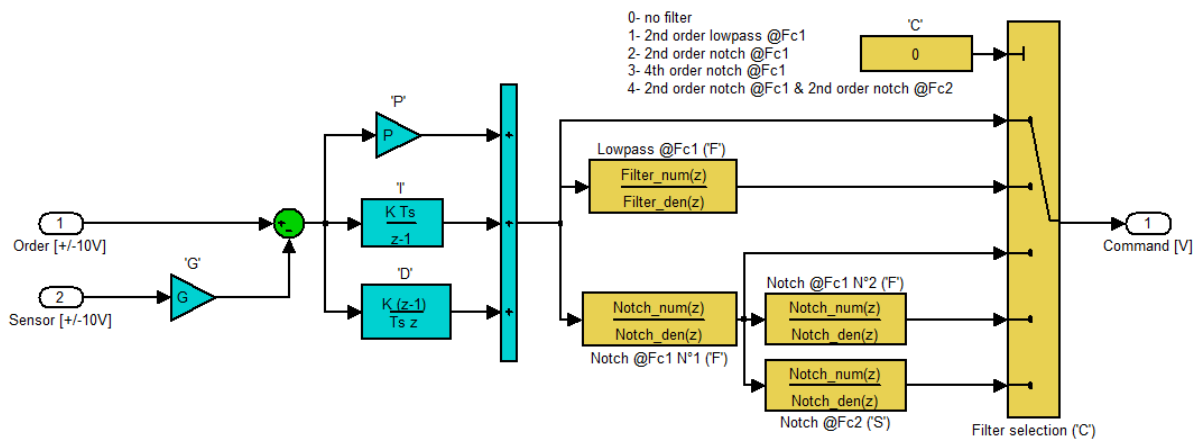

Figure X-1: Controller structure.

XI. COMMUNICATION INTERFACE

The digital link serves to set the control parameters and can also serve to send the commands and read sensors.

The CCBu20 can be interfaced and configured manually over the serial link.

Alternatively, it offers compatibility with the HDPM45 GUI provided by CTEC for its controllers (see section XI.3) when 57600baud is selected.

Note: The communication becomes active as soon as the green “Power” indicator lights. The communication remains active even in Standby of Fault condition.

XI.1. SETTINGS

SPEED

The digital communication speed is user configurable (see command 'b' in the list of command).

On delivery, the switch N°3 is set in up position and force the serial rate to 57.6kbps. This allows the user to use a standard slow rate when connecting the CCBu20 to a computer, for applications where latency and refresh rates are not constraints. This is also the baud rate for communicates with the CTEC HDPM.

The user configurable speed can be selected when setting the switch N°3 in down position. The serial rate is 937.5 kbps by default but can be user defined with a command (please refer to the List of commands).

When interfacing with a fast-digital supervisor, the 937.5kbps rate and compact data format are recommended to reduce latency and increase the refresh rate.

FORMAT

The digital interface is a serial full-duplex link. RS422 signaling is implemented to reach high transmission rate.

The other parameters of the serial communication are the following:

- 8 data bits,
- 1 stop bit,
- No parity bit,
- RTS/CTS flow control.

Data is in ASCII format to allow the user to adjust the CCBu20 configuration using a serial terminal on a computer. If installed, Hyperterminal can be used. If no terminal is installed, the user can use other Terminal softwares such as Puttytel (<http://www.chiark.greenend.org.uk/~sgtatham/putty/download.html>).

Note: To interface with a computer with only USB ports, the user can use a USB-RS422 converter, such as FTDI converters: <http://www.ftdichip.com/Products/Cables/USBR422.htm>. In this case, a serial interface will appear on the computer (virtual COM port) when connected. The user should install the drivers on the computer before connecting the converter. The drivers are available on the FTDI website:

<http://www.ftdichip.com/Drivers/VCP.htm>

XI.2. STANDARD FORMAT

COMMAND FORMAT

The commands consist in a chain of characters that will be interpreted by the electronics before it is applied. The number of characters in a command is not fixed, but it cannot exceed 20 characters, nor be shorter than 3 characters. The command structure is as follows:

“COMMAND CHARACTER + VALUE + EXECUTION CHARACTER”

- The command always starts with a single command character. The list of command characters and their use is given in Section 0.
- The command character is always followed by a parameter value in decimal. In this field, only numeric characters are allowed, as well as signs ('+' or '-'), and decimal separator '.'. It is not authorized to leave this field empty. If unused it can be filled with '0'. The parameters to the CCBu20 can be integer or floating values.
- The command is always ended by the execution character 'E' (in capital letter). This character indicates the end of the command. After this character, the electronic executes the command and answers or acknowledges. Another command can then be issued.

Warning: Do not use carriage return or “enter” button of the keyboard to send the command, as this will introduce an invalid character in the chain. The commands are only executed with 'E' character.

ANSWER FORMAT

The format of the CCBu20 answer to the command is the following:

“N x 4 DATA BYTES (OPTIONAL) + ACKNOWLEDGEMENT CHARACTER”

For commands used to request feedback from the electronics, the answer starts with N x 4 data bytes. Each packet of 4 data bytes represents a 32bits signed integer value. Depending on the request, the CCBu20 will reply with a different number of data packets before acknowledging. The MSB is sent first, ie LSB is sent last. **Thus, those data bytes should not be interpreted as ASCII characters but directly as pure data bytes.**

For commands with no feedback, the first field is empty, i.e. no data bytes are transmitted.

The last character of the answer is always the acknowledgement character, which indicates that the command was received and applied:

- The acknowledgement character is 'X' (0x58) when the command has been properly applied.
- The acknowledgement character is 'Y' (0x59) when an error has been detected in the command. In that case, the command is not applied. This happens in particular in the following cases:
 - The command is unknown.
 - The command length exceeds 20 characters.
 - The command length is less than 3 characters.
 - The field value contains non numeric characters.
 - The field value is empty.
 - The field value is out of range for the corresponding command.

LIST OF COMMANDS

| Command character | Description of the command | Parameter range | Examples |
|-------------------|--|--|---|
| 'V' | <p>This command allows selecting the axis on which the next digital commands will be applied.</p> <p>Once an axis is selected, all following commands apply to this same axis, until another selection is made.</p> <p>Upon power-up, the axis X is selected by default.</p> | <p>1: The axis X is addressed</p> <p>2: The axis Y is addressed</p> | 'V1E' selects the X axis for the next commands. |
| 'B' | This command allows selecting open-loop or closed-loop operation. | <p>0: Open-loop operation of the selected axis</p> <p>1: Closed-loop operation of the selected axis</p> | 'B1E' selects closed-loop operation. |
| 'T' | <p>This command allows between digital command or analog command.</p> <p>This configuration is ignored if configuration switch N°2 is up. In that case, analog commands are used on both axis.</p> | <p>0: Analog command 'AIX/Y' is used for the selected axis</p> <p>1: Digital command is used for the selected axis</p> | 'T1E' selected the digital command. |
| 'Z' | <p>This command sets the digital order value for the selected axis.</p> <p>This command should be used for sending commands in real-time (faster execution time).</p> <p>The digital order will be used only if the corresponding axis is setup for working with digital commands.</p> | [-10V ; +10V] | 'Z2.435E' sets a digital order of 2.435V. |
| 'W' | <p>This command sets the digital order value for the selected axis and saves it to the memory (longer execution time).</p> <p>The digital order will be used only if the corresponding axis is setup for working with digital commands.</p> | [-10V ; +10V] | 'W-5.335E' sets a digital order of -5.335V. |
| 'M' | <p>This command sets the upper limit for the output to the power amplifier, for the selected axis. If the controller output is larger, it will be saturated to this value.</p> <p>The upper limit has to be larger than the lower limit.</p> | [-1V ; +7.5V] | 'M4.678E' sets the upper limit of the output at 4.678V. |
| 'N' | <p>This command sets the lower limit for the output to the power amplifier, for the selected axis. If the controller output is smaller it will be saturated to this value.</p> <p>The lower limit must be smaller than the upper limit.</p> | [-1V ; +7.5V] | 'N-0.65E' sets the lower limit of the output at -0.65V. |

| | | | |
|-----|---|--|---|
| 'O' | This command allows to correct an intrinsic strain gauge offset by adding a voltage to the output of the sensor conditioner. | [-5V ; +5V] | 'O-1.23E' sets the output 'SX' to -1.23V (if the intrinsic offset is 0) |
| 'P' | Sets the proportional term P of the PID controller, for the selected axis. | $P \geq 0$ | |
| 'I' | Sets the integral term I of the PID controller, for the selected axis. | $I \geq 0$ | |
| 'D' | Sets the Derivative term D of the PID controller, for the selected axis. | $D \geq 0$ | |
| 'F' | Sets the cut-off frequency Fc1 of the notch filter and the low-pass filter, for the selected axis. | $Fc1 \geq 0$ | |
| 'S' | Sets the cut-off frequency Fc2 of the second notch filter (activated for C=4), for the selected axis. | $Fc2 \geq 0$ | |
| 'C' | Selects the output filter to be applied on the PID output, for the selected axis. | 0: No filter 1: 2nd order Low-pass filter (Fc1). 2: 2nd order Notch filter (Fc1) 3: 4th order Notch filter (Fc1) 4: 2 x 2nd order Notch filters in series with two different frequencies (Fc1 and Fc2) | |
| 'G' | <p>Sets the linear gain of the sensor feedback, for the selected axis.</p> <p>This gain can be used to invert sensor feedback or to rescale the order magnitude (since the order gain corresponds to the sensor gain).</p> <p>This only changes the gain of the sensor in software, the analog sensor signals are not impacted.</p> <p>This gain is set to 1 by default. In standard configurations, it is recommended to leave it unchanged.</p> | | 'G1E' sets the linear gain of the sensor feedback to 1. |
| 'Q' | <p>This command requests the sensor feedback. This command operates in the same manner whatever the axis selected.</p> <p>The electronic answers with 4 data bytes followed by acknowledgement character. The 4 data bytes represent a signed integer value. Based on this value, the status of the system is as follows:</p> <p>Sensor feedback [V] = Value / 3276.8</p> | 1: Sensor feedback for axis X is requested. 2: Sensor feedback for axis Y is requested. | <p>'Q2E' requests the sensor feedback for axis Y.</p> <p>The electronics will reply 0xFFFFEAE258: -> 0xFFFFEAE2 corresponds to a -1.65V sensor feedback. -> 0x58 at the end corresponds to the 'X' acknowledgement.</p> |

| | | | |
|-----|--|---|---|
| 'R' | <p>This command requests the parameter set of one axis. This command operates in the same manner whatever the axis selected.</p> <p>The electronic answers with 15 x 4 data bytes followed by acknowledgement character. Each 4 data bytes represent a signed integer value corresponding to a single parameter. The parameter readback description is given in the Erreur ! Source du renvoi introuvable..</p> | <p>1: Requests the parameter set for axis X</p> <p>2: Requests the parameter set for axis Y</p> | <p>'R1E' requests the parameter set for axis X.</p> |
| 'b' | <p>This command allows the user to change the baud rate in fast mode i.e. when the configuration switch N°1 is mounted.</p> <p>The effective baud rate (in Mbps) is:</p> $BR = 11.25 / (Reg + 1)$ $Reg = 11.25 / BR - 1$ <p>Please refer to Erreur ! Source du renvoi introuvable. for typical values.</p> | <p>'Reg' is in the range:</p> <p>[0 ; 65535]</p> <p>[0 ; 0xFFFF]</p> | <p>'b11E' set the baud rate to 937.5kbps</p> |

Table XI-1: Description of the commands

| Desired baud rate (kbps) | Parameter value | Real baud rate (kbps) | Error |
|--------------------------|-----------------|-----------------------|--------|
| 9600 | 1171 | 9599 | -0.01% |
| 19200 | 585 | 19198 | -0.01% |
| 38400 | 292 | 38396 | -0.01% |
| 57600 | 194 | 57692 | 0.16% |
| 115200 | 97 | 114796 | -0.35% |
| 230400 | 48 | 229592 | -0.35% |
| 460800 | 23 | 468750 | 1.73% |
| 921600 | 11 | 937500 | 1.73% |

Table XI-2: Parameter value for typical baud rate

| Position in CCBu20 answer | Description | Conversion / Interpretation |
|--|-------------------------------------|---|
| 1 (first 4 bytes sent) | Analog or digital command selection | No conversion required: 0: The axis is configured for analog command. 1: The axis is configured for digital command. |
| 2 | Digital command | Command [V] = Value / 3276.8 |
| 3 | Open-loop or closed-loop selection | No conversion required: 0: The axis is configured in open loop. 1: The axis is configured in closed loop. |
| 4 | Parameter P | P = Value / 65536 |
| 5 | Parameter I | I = Value / 65536 |
| 6 | Parameter D | D = Value / 65536 |
| 7 | Output filter selection | No conversion required: 0: No filter 1: 2nd order Low-pass filter (Fc1). 2: 2nd order Notch filter (Fc1) 3: 4th order Notch filter (Fc1) 4: 2 x 2nd order Notch filters in series with two different frequencies (Fc1 and Fc2) |
| 8 | Fc1 cutoff frequency | No conversion required: Fc1 = Value |
| 9 | Fc2 cutoff frequency | No conversion required: Fc2 = Value |
| 10 | Output upper limitation | Upper limit [V] = Value / 3276.8 |
| 11 | Output lower limitation | Lower limit [V] = Value / 3276.8 |
| 12 | Sensor feedback gain | Gain = Value / 65536 |
| 13 | Firmware version | No conversion required: Version = Value For instance, a value of 100 means version 1.00 |
| 14 | Serial number | No conversion required: Serial number = Value For instance a value of 15001 means serial number 15-001 (year of manufacturing 2015, CCBu20 N°1) |
| 15 (last 4 data bytes before acknowledgement) | Not used | |
| 16 | Acknowledgement character 'X' | |

Table XI-3: Description of parameter set read back

Notes:

- Do not forget to send the 'V' command to select the axis for which you want the parameters to be adjusted.
- When a parameter of the CCBu20 is modified, the new parameter value is automatically saved in a non-volatile memory. The parameters of the CCBu20 are automatically recalled on startup, so that the user does not have to reconfigure the board on every power-up.
- Since those commands write the memory, their execution time is longer.
- This does not apply on 'V' and 'Z' commands, which modify parameters but do not write to the memory. Consequently, their execution is faster.

XI.3. HDPM45 GUI

The CCBu20 is compatible with the HDPM45 GUI that allows configuring the control law with a computer over a serial COM port. If the computer does not feature a serial COM port, a serial port can be emulated on a computer using a RS422 to USB computer (check section XI.1 for more details).

The last version of the HDPM45 software can be downloaded here:

<https://www.cedrat-technologies.com/fr/produits/interface-graphique.html>

For the use and installation of the HDPM45 software, refer to the section 4 and 5 of the UC45 user's manual, which can be found online:

<http://www.cedrat-technologies.com/en/products/users-manual/electronics.html>

XII. POWER SUPPLY, POWER CONSUMPTION, OUTPUT CURRENT CAPABILITY

The CCBu20 is supplied with a DC voltage between +24V and +28V. The power supply return is the CCBu20 ground reference, and it is connected to the packaging for shielding.

Warnings:

- The supply voltage should never exceed +32Vdc. Exceeding +32Vdc will lead to permanent damage of the CCBu20.
- The power supply should have a peak current capability of at least 1.5A, which is required during startup. If you are using a current limited supply, set the current limitation to at least 1.5A, to avoid any problem during startup.
- Maximum peak output power may require a power supply peak current as high as 5A peak.

The power consumption of the CCBu20 is approximately 6W in static operation. Static operation means that the CCBu20 is enabled, no error is detected, and the commands are steady, i.e. the system is not moving. In dynamic operation, i.e. when the system is moving, the power consumption will increase linearly with the increase of output current to the piezo-ceramics. The CCBu20 accepts a maximum 1A continuous supply current, which means that the maximum power consumption is directly linked to the supply voltage, as shown on the Figure XII-1:

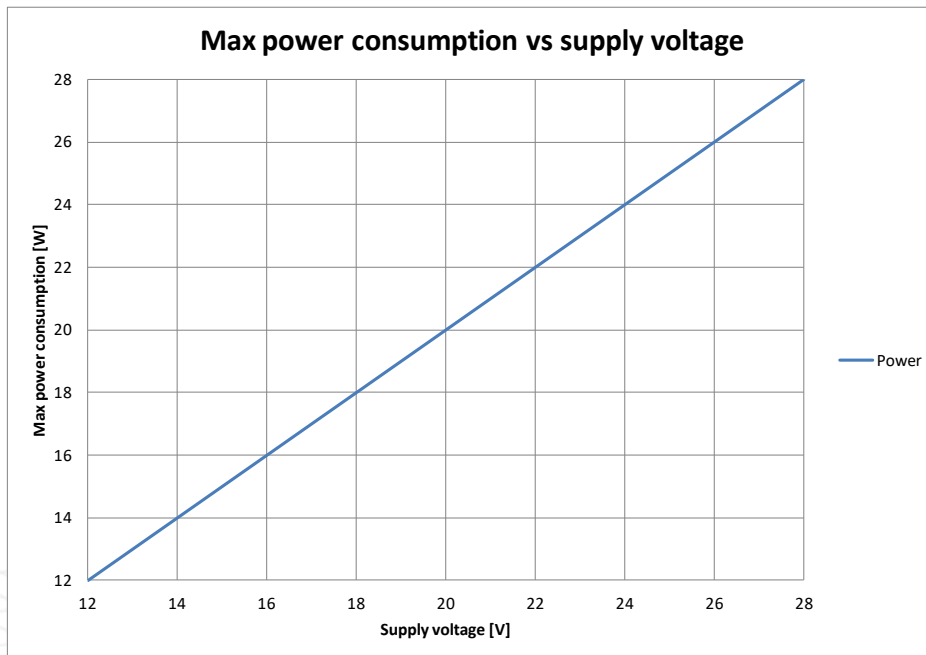

Figure XII-1: Maximum power consumption versus supply voltage.

The CCBu20 is capable of outputting a maximum output current of 35mA per channel, for +28Vdc supply, leading to approximately 28W power consumption. With 35mA per channel, this means in total 105mA for the three output channels (two axis outputs and one push-pull rail). For supplies lower than +28Vdc, the maximum output current is reduced linearly as shown on the Figure XII-2:

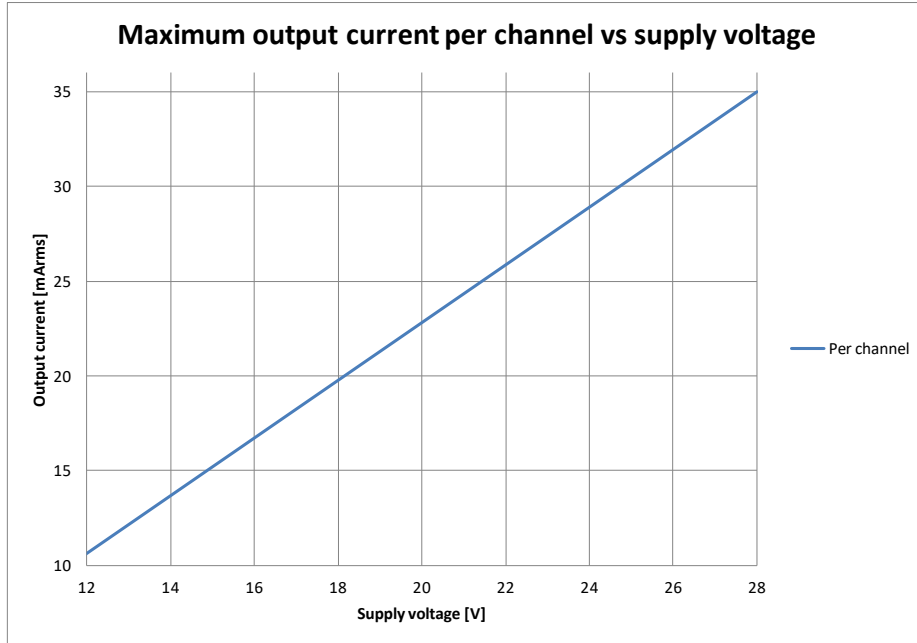

Figure XII-2: Maximum output current per channel versus supply voltage.

For applications where the output current demands is not equal between channels, or for which channels are not used, the analysis can be done based on the maximum total output current. The maximum total output current versus supply voltage is given on the Figure XII-3. **This RMS output current budget can be distributed unevenly between the three channels, but it should never exceed 35mA rms for one channel.**

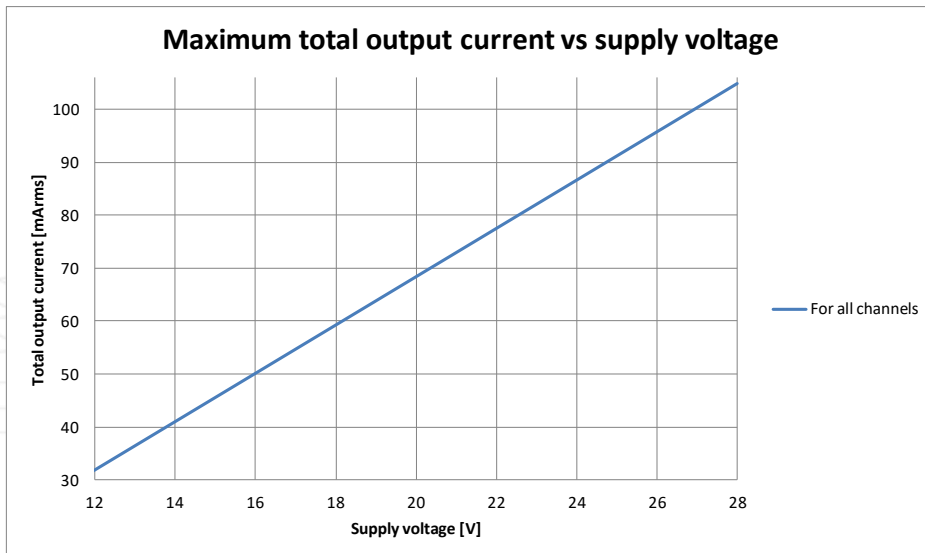

Figure XII-3: Maximum total output current versus supply voltage.

The power consumption of the CCBu20 is linked to the total RMS output current to the actuators, and the relationship is given by Figure XII-4:

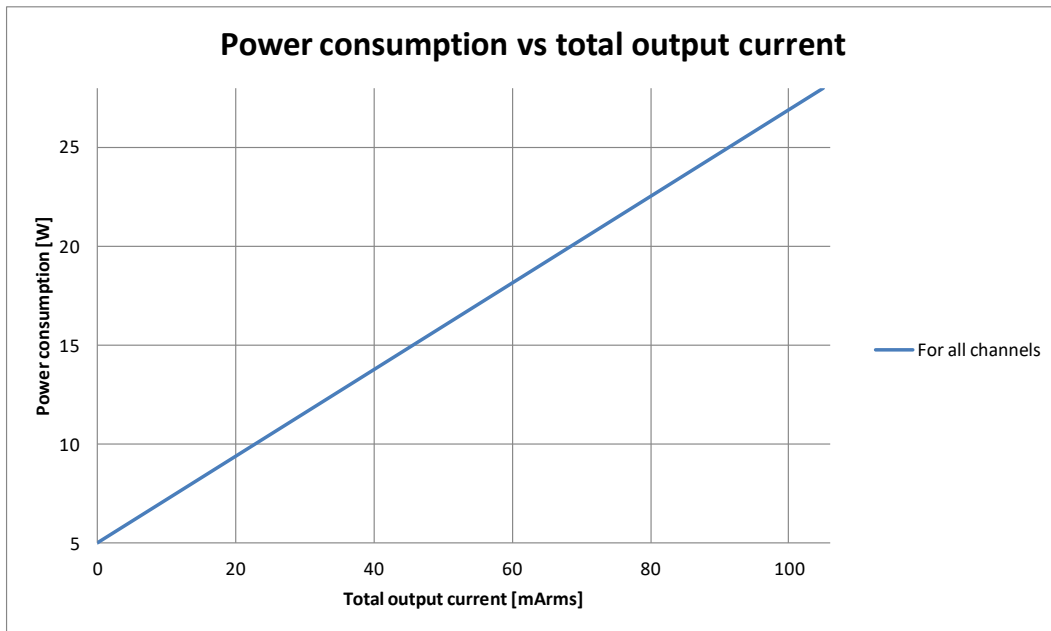



Figure XII-4: Power consumption versus total output current.

XIII. THERMAL INTERFACE

WARNING: Risk of burns



The product and especially its thermal interface can be very hot (>100°C) when operating and after operation. There is a risk of burns when touching the packaging.

The bottom plate of the CCBu20 is the heat sinking surface (see Figure XIII-1). To prevent from overheating at high temperature and/or high power, the user has to implement proper heat sink for cooling. This can be done by attaching a spare heatsink, or directly by attaching the CCBu20 on a surface providing heat dissipation.

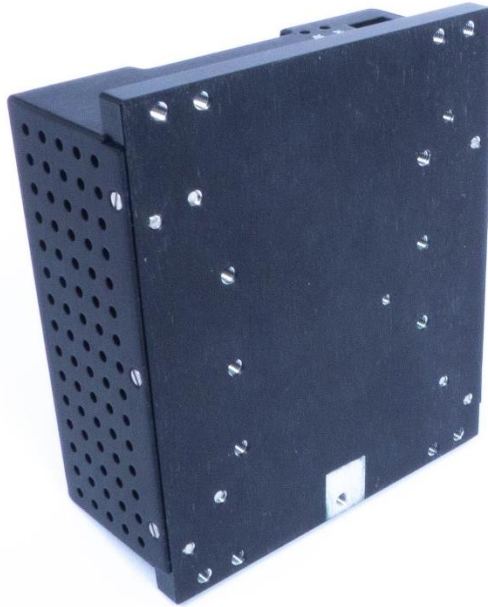

Figure XIII-1: Heat sinking surface, with standard vertical connectors.

The requirement for the heat sink efficiency depends both on the maximum ambient temperature of the application and the CCBu20 power consumption (estimated on the Figure XII-4). The maximum thermal resistance of the heat sink from the CCBu20 surface to ambient is computed using the following equation:

$$R_{\text{heatsink}} = ((125 - T_{\text{max}}) / P_{\text{CCBu20}}) - 0.5$$

Where R_{heatsink} is the thermal resistance of the heatsink in °C/W, T_{max} is the maximum ambient temperature in °C, and P_{CCBu20} is the power consumption of the CCBu20 in W.

Based on this equation, maximum R_{heatsink} can be computed in two specific cases:

- At +70°C, depending on the power consumption, on the Figure XIII-2.
- At 28W, depending on the ambient temperature, on the Figure XIII-3.

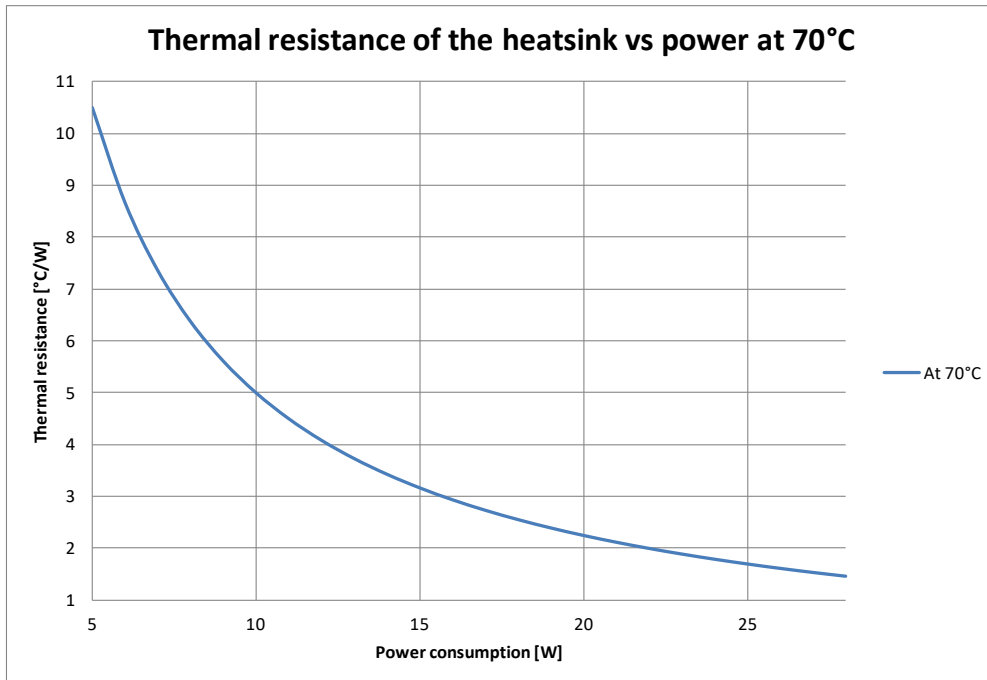

Figure XIII-2: Maximum thermal resistance depending on the power consumption, at +70°C.

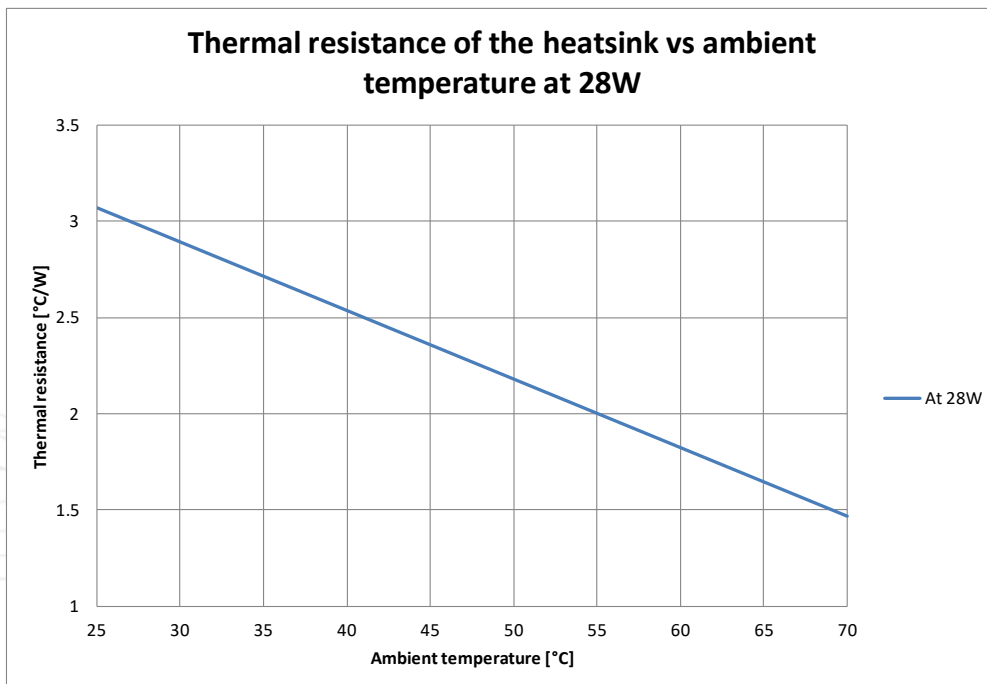

Figure XIII-3: Maximum thermal resistance depending on the ambient temperature, at 28W.

XIV. TROUBLE SHOOTING FORM

In case of trouble or breakdown with the electronic device, this form must be completed by the customer in order to:

- allow Cedrat Technologies to authorise the product return back to the factory,
- help Cedrat Technologies in repairing it.

Product: Please give mention here the references and delivery date,

History: Please summarise here every action which has been performed with the device since the delivery,

Problem description: Please describe here the problems faced with the electronics and which are not described in the paragraph 3,

Notations: Please define here the short term used for external devices plugged in the electronics in order to make the writing of “problem identification” easier,

Problem identification: Please summarise and describe here, using the “notations”, the operation that could lead to problem identification,

Action: Please mention and update here every action undertaken by yourself, by Cedrat Technologies or by your local vendor,

Please note that you need to get the authorisation from CEDRAT TECHNOLOGIES before sending back the hardware.

XV. APPENDIX 1: MECHANICAL ICD

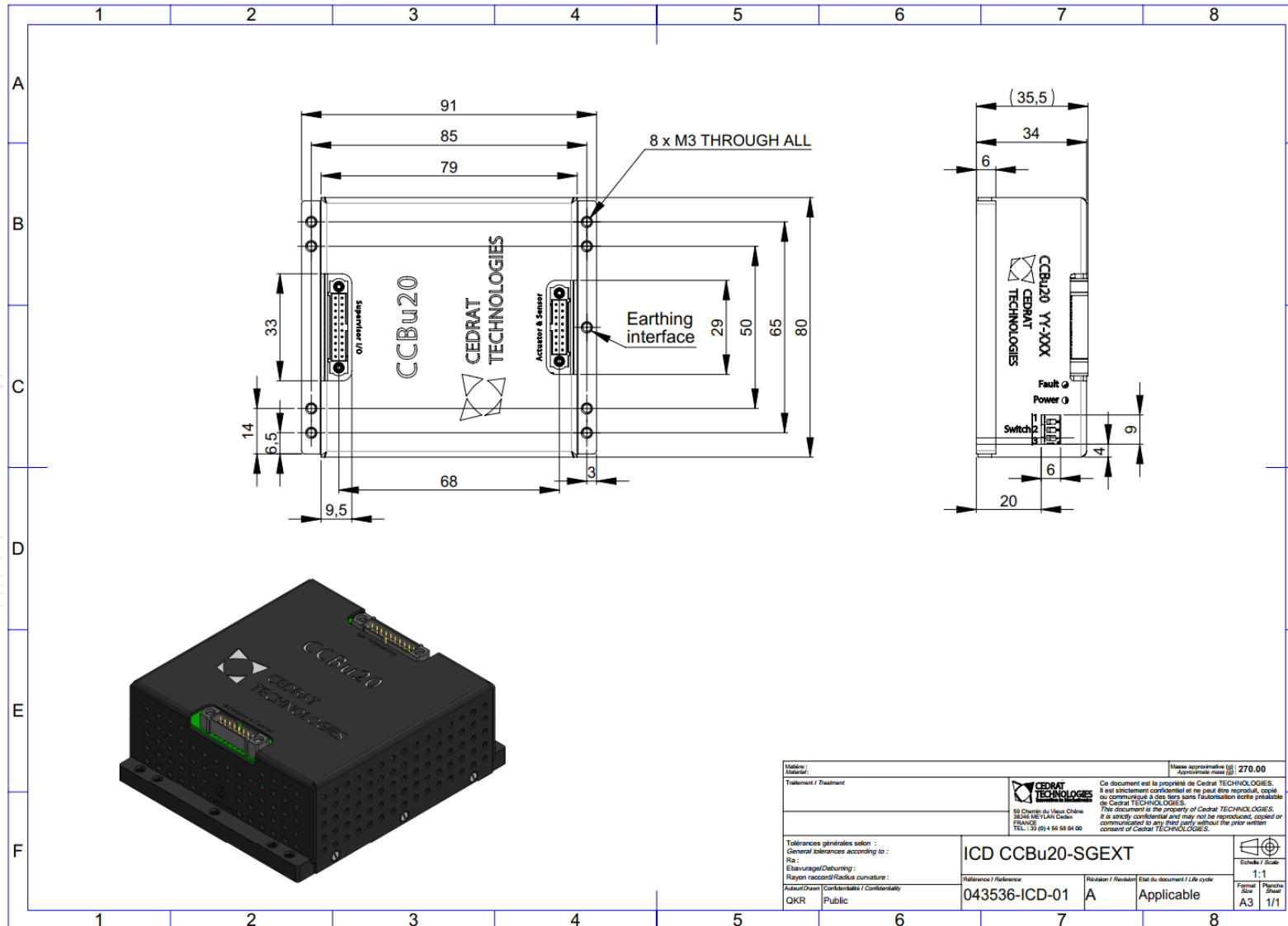

XVI. APPENDIX 2: SUPERVISOR INTERFACE BOARD ACCESSORY

The SIB (Supervisor Interface Board) is an optional accessory.

This is a supervisor harness break board, that may be used for laboratory and development purpose, before a final integration of the CCBu20.

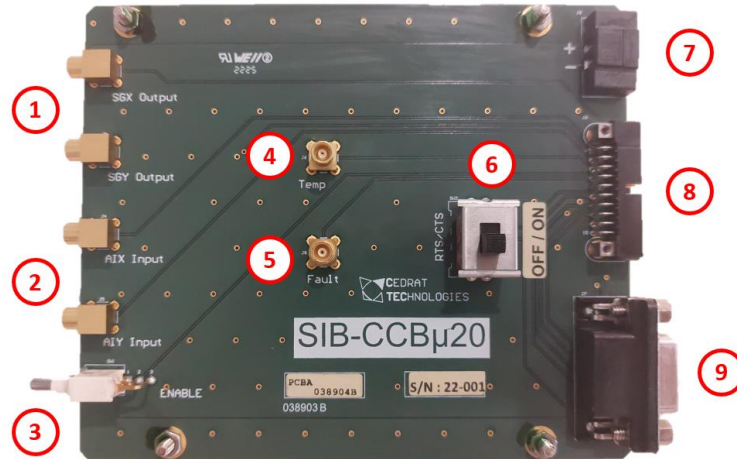

Figure XVI-1: SIB description

| N° | Description | Supervisor pinout | Connector |
|----|---|--|---|
| 1 | SGX and SGY analog outputs (sensor outputs) | 1 (SY) 2 (SX) 6 (AGND) | MCX socket |
| 2 | AIX and AIY analog inputs (order inputs) | 3 (AIY) 4 (AIX) 6 (AGND) | MCX socket |
| 3 | Enable switch | 8 (Enable) 17,18 (GND) | Mechanical switch |
| 4 | Mechanism analog temperature output | 5 (T°C) 6 (AGND) | MCX socket |
| 5 | Fault digital output | 7 (Fault) 17,18 (GND) | MCX socket |
| 6 | RTS/CTS (used to disable RTS/CTS on supervisor side, on specific CCBu20 versions without RTS/CTS) | | Mechanical switch |
| 7 | 28V power supply input | 19,20 (Vdc) 17,18 (GND) | Phoenix Contact Socket: 1727566 + plug: 1714977 |
| 8 | Harness to CCBu20 supervisor connector | All | Harwin Socket: M80-5402042 + provided harness |
| 9 | Digital RS422 communication | 9-18 (CTS-, CTS+, RTS-, RTS+, TX-, TX+, RX-, RX+, GND) | SUBD-9 + recommended : FTDI USB-COM422-PLUS1 |