

XY PIEZOELECTRIC STAGE - PRODUCT AND WARRANTY INFORMATION



Version : 3.5
Date 15/04/2013

TABLE OF CONTENTS

1	PRESENTATION	3
2	MOUNTING PROCÉDURE	3
2.1	Mechanical mounting	3
2.2	Electrical connections.....	4
3	DRIVING THE XY STAGE IN PUSH - PULL MODE	5
3.1	Connction schemes for XY25XS & XY200M.....	6
4	WARRANTY CONDITIONS AND EXCEPTIONS.....	7
5	INSPECTION UPON RECEIPT	7
6	ANNEX 1: XY25XS TECHNICAL CHARACTERISTICS	8
7	ANNEX 2: XY200M TECHNICAL CHARACTERISTICS	11
8	ANNEX 3: XY95ML INTERFACE	13

1 PRESENTATION

The piezoelectric stages from CEDRAT TECHNOLOGIES SA are using multilayer actuators.

Piezoelectric Actuators must be handled carefully. Lifetime of Piezoelectric Multilayer actuators is not limited by wear. They can perform millions of cycles without loss of performance provided they are operated under suitable conditions.

The lifetime of a Piezoelectric Multilayer Actuators is a function of many combined parameters; the most influencing being the applied voltage, the temperature and the humidity. For maximum lifetime, operating voltage should be minimized, especially when they are used in static conditions.

Tests have shown that the lifetime is reduced significantly, if the actuator is maintained continuously at the maximal operating voltage. For instance, a Piezoelectric Multilayer Actuator can be definitively damaged, if submitted to the maximal operating voltage (e.g.: high electrical field up to 1.5 kV/mm) during more than one hour.

A high self heating of the piezo ceramic may occur during a long use in dynamic (high frequency) operation. This can lead to depolarization or electrical breakdown of the piezo ceramic.

The mechanical installation or the induced moments under operation by the mechanism are the main sources of failure.

2 MOUNTING PROCÉDURE

2.1 Mechanical mounting

XY stages are composed of 2 sub systems, which are:

- the frame, generally attached,
- the moving frame, including the piezoelectric actuators and moving the payload.

To get good results and a safe mechanism, it is important to use the foreseen mechanical interfaces both on the frame and on the moving frame (see annex 2).

In any case, please take care during the mounting procedure, to avoid excessive moments in the moving frame, when tightening the screws

The correct order for the operations is the following:

1. Tighten the payload onto the moving frame
2. Tighten the frame onto the attachment basis : use standard screws and a progressive tightened procedure (each screws is first pre tightened and in a second step tightened at the correct standard torque)

2.2 Electrical connections

Electrical connectors are used for the stage driving, and in option position sensors.

During the mounting operation, electrical charges can be produced by the stage, through any applied force and the direct piezoelectric effect.

Before the electrical connection, please refer to the electrical connection scheme to avoid exchanging the driving and the sensing connectors. Labels have been stuck on the stage to make easier this operation. In actuator connector side the label is "PZT", in gauge side the label is "SG".

The piezoelectric stage can be delivered with a full bridge of strain gauges (SG option) per axis. For these actuators, purchased without the sensing electronic, the connection between the strain gauges and the electronic must be realized with the customer: the electrical interface is described below:

The Strain Gauges used by CEDRAT TECHNOLOGIES display an Ohmic resistance of 350Ω for all the actuators and mechanisms.

For the strain gauges 350Ω the driving voltage ($V_{cc}-GND$) should not be higher than 10V.

The reduction of the driving voltage reduces the dissipated power and the related thermal effect, but also reduces the sensitivity of the bridge.

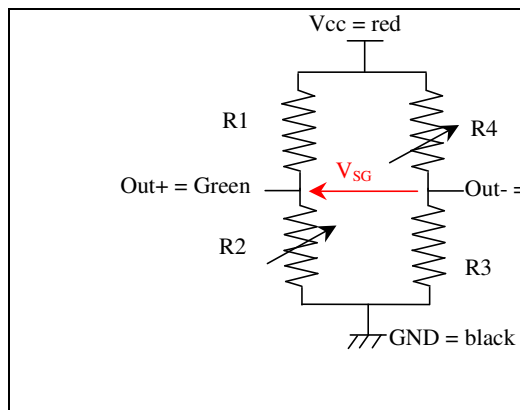

Figure 1 : Schematic of the Strain Gauges bridge

3 DRIVING THE XY STAGE IN PUSH – PULL MODE

Please refer to the LA75 reference manual, section S5.4.

Axis conventions and connections schemes are presented in section 3.1 et 3.2 of this manual (top view of the stage).

CAUTION: *It is recalled that the actuator must be excited between -20 V and 150 V. A higher voltage will damage the stage.*

In case the stage is delivered without the driving and control electronic from Cedrat Technologies, the driving connector is equipped with 6 AWG26 wires (see pictures).

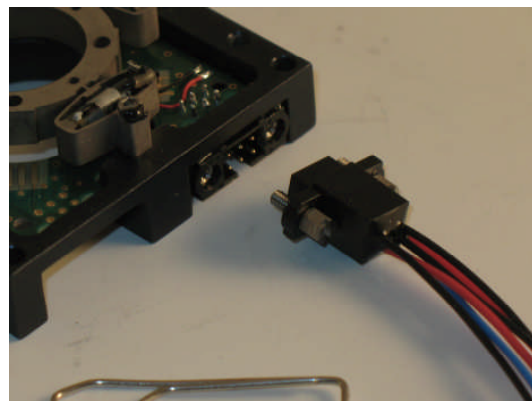
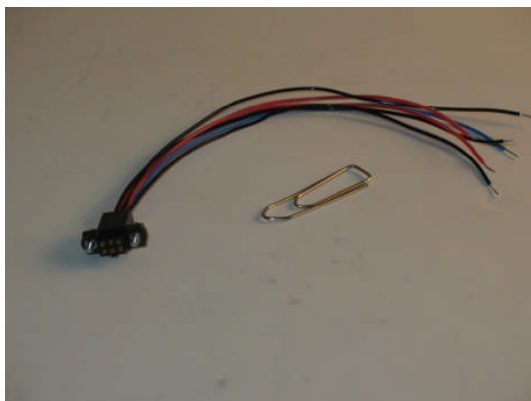

The table here below shows the relationship between the PZT input pin connector and the wire colour.

1	Red AWG26
2	Blue AWG26
3	Red AWG26
4	Black AWG26
5	Black AWG26
6	Black AWG26

3.1 Conception schemes for XY25XS & XY200M

Both stages XY25XS & XY200M have the same electrical interface.

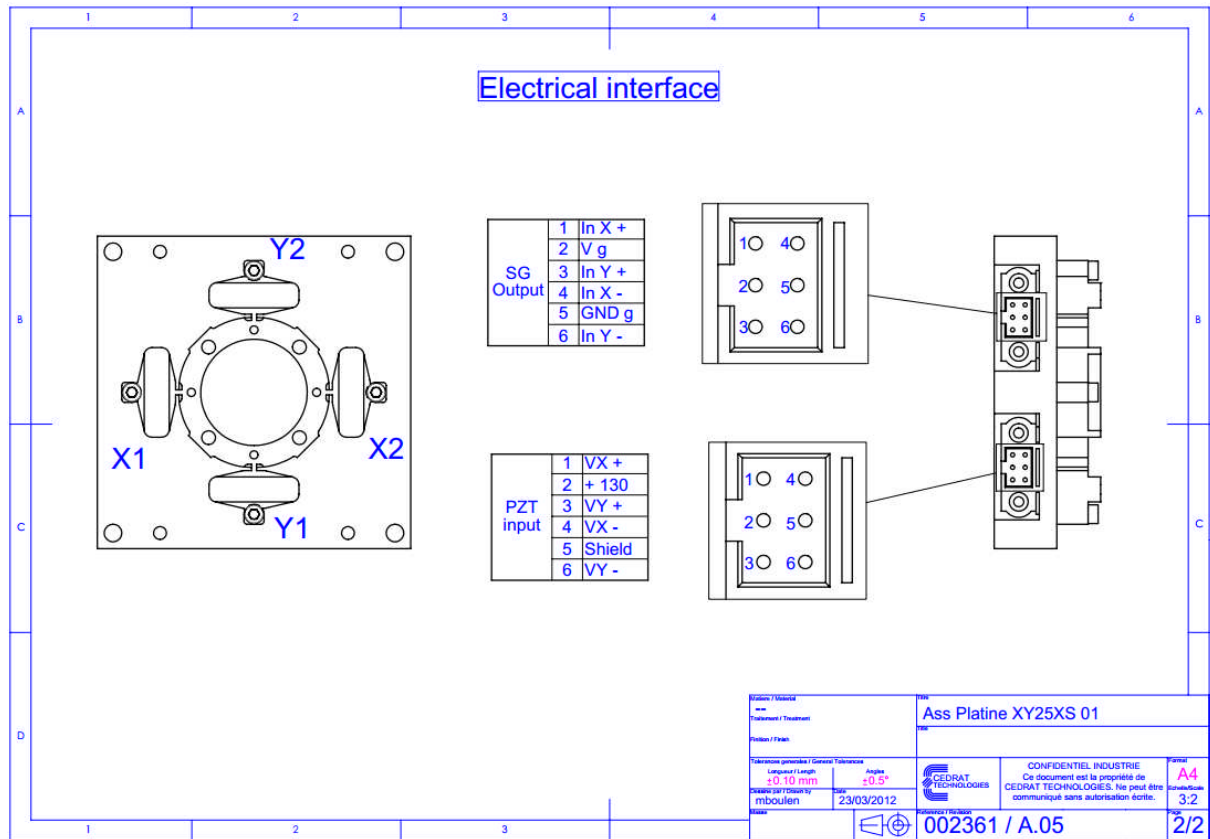

XY25XS – XY200M STAGES			
	N° PIN	Name	FUNCTION
Strain gauge	6	In Y-	Sensor Signal Y -
	5	Gnd SG	Strain gauge Ground
	4	In X-	Sensor Signal X-
	3	In Y+	Sensor Signal Y+
	2	Vcc SG	Strain Gauge Vcc
	1	In X+	Sensor Signal X+
Stage drive	6	VY-	Piezo Y return
	5	Shield	Shield
	4	VX-	Piezo X return
	3	VY+	Piezo Y signal
	2	+130 V	VCC
	1	Vx+	Piezo X Signal

4 WARRANTY CONDITIONS AND EXCEPTIONS

The equipment is warranted for one year, including parts and labor, and only under standard technical conditions as outlined above and expressly mentioned in the technical data sheet. Repairs will be carried out at Cedrat Technologies or through your vendor.

Interventions or attempts to service or repair the Actuators by any unauthorized persons will invalidate this warranty.

In addition, this warranty will not apply if the APA is subjected to any of the following:

- improper handling, including, but not limited to, shocks and abrasions
- improper installation, including, but not limited to, excessive mechanical forces and moments, failure to use the standard electrical and mechanical interfaces
- excessive voltage, including, but not limited to, peak values outside the recommended operating range, DC values applied for excessive time periods
- inappropriate environmental conditions, including, but not limited to, high temperatures or high humidity
- attempt to modify the standard electrical connection of the APA (soldering out of electrical wires, plugs change,...) or the standard mechanical interfaces

5 INSPECTION UPON RECEIPT

This product has been inspected and shown to operate correctly at the time of shipment, as verified by the Factory Verification form that accompanies the actuator.

Immediately upon receipt of the product, it should be inspected carefully for any signs of damage that may have occurred during shipment. If any damage is found, a claim should be filed with the carrier.

The package should also be inspected for completeness according to the enclosed packing list. If an order is incorrect or incomplete, contact your distributor.

If a device requires service, please contact Cedrat Technologies or your local vendor. Please include the device model and serial number in all correspondence with Cedrat Technologies or your vendor.

6 ANNEX 1: XY25XS TECHNICAL CHARACTERISTICS

Table of standard properties of use and measurement

The properties defined in the table below, are set up according to the technical conditions of use and measurement. These properties are warranted within their variation range and in compliance with the standard technical conditions of use.

Properties XY25XS	Standard technical conditions	Unit	Nominal values	Min. values	Max. values
Notes		-	-	-	-
Sensor options	SG, ECS	-	-	-	-
Mastered motions	TX, TY	-	-	-	-
Max. no load displacement	Quasistatic excitation, blocked-free	μm	25	23	29
Out of plane Z displacement		μm	0.50	0.30	0.70
Max. parasitic Z rotation		μrad	50.00	42.50	57.50
Max. parasitic XY rotation		μrad	10.00	8.50	11.50
Blocked force	Quasistatic excitation, blocked-free	N	40	32	48
Stiffness	Quasistatic excitation, blocked-free	N/μm	2.50	2.00	2.75
Unloaded resonance frequency (in the actuation's direction)	Harmonic excitation, blocked-free, on the admittance curve	Hz	3000	2550	3600
Unloaded response time	Quasistatic excitation, blocked-free	ms	0.17	0.15	0.19
Capacitance (per electrical port)	Quasistatic excitation, blocked-free, on the admittance curve	μF	0.50	0.45	0.65
Resolution		nm	0.25	-	-
Height		mm	20.00	19.90	20.10
Diameter		mm	45.00	44.90	45.10
Mass		g	80.0	-	-
Standard mechanical interface (payload)	1 Ø 17 mm hole + 4 Ø1.8mm on Ø 20 mm	-	-	-	-
Standard mechanical interface (frame)	4 Ø 2.8 mm holes on □ 45	-	-	-	-
Standard electrical interface	2 RG178B/U coaxial cables with Harwin connectors	-	-	-	-

Properties standard technical conditions of use and measurement

- Free-free** : The actuator is not fixed
- Blocked-free** : The actuator is fixed to a mechanical support assumed infinitely stiff
- Quasistatic excitation** : AC voltage between -20 and 150 V at 1 Hz
- Harmonic excitation** : Voltage of 0.5 V_{rms}, sinusoidal mode from 0 to 100 kHz
- Max. harmonic excitation** : Voltage defined by the measurement of max. displacement, sinus at resonance frequency
- Displacement measurement** : Laser interferometer, capacitive displacement sensor
- Admittance measurement** : HP 4194 A or Cypher C60 electrical impedance analyser
- Environment** : Ambient temperature (15-25°C) and dry air (Humidity < 50 % rH)

Any technical conditions of use, different from those defined above, can lead to temporary or definitive alterations of properties. Thank you to contact CEDRAT TECHNOLOGIES before using actuators under non standard technical conditions.

Factory tests carried out

- Test 1 : Electrical admittance vs. Frequency, free-free
- Test 2 : Displacement vs. input voltage

Extra factory tests

- Test 3 : Gain and linearity of the sensor
- Test 4 : Step response in closed loop
- Test 5 : Stability in closed loop

Mechanical interface

- | | | |
|--|---|---|
| <input type="checkbox"/> [FI] Flat Interface | <input type="checkbox"/> [H] Flat Interface with hole | <input type="checkbox"/> [TH] Flat Interface with threaded hole |
| <input type="checkbox"/> [SV] Specific version | <input type="checkbox"/> [FF] Free-free Interface | <input type="checkbox"/> [SI] Specific interface |

Available options

- | | | |
|--|--|--|
| <input checked="" type="checkbox"/> [SG] Strain gauges | <input type="checkbox"/> [ECS] Eddy Current Sensor | <input type="checkbox"/> [NM] Non-magnetic |
| <input type="checkbox"/> [VAC] Vacuum | <input type="checkbox"/> | |

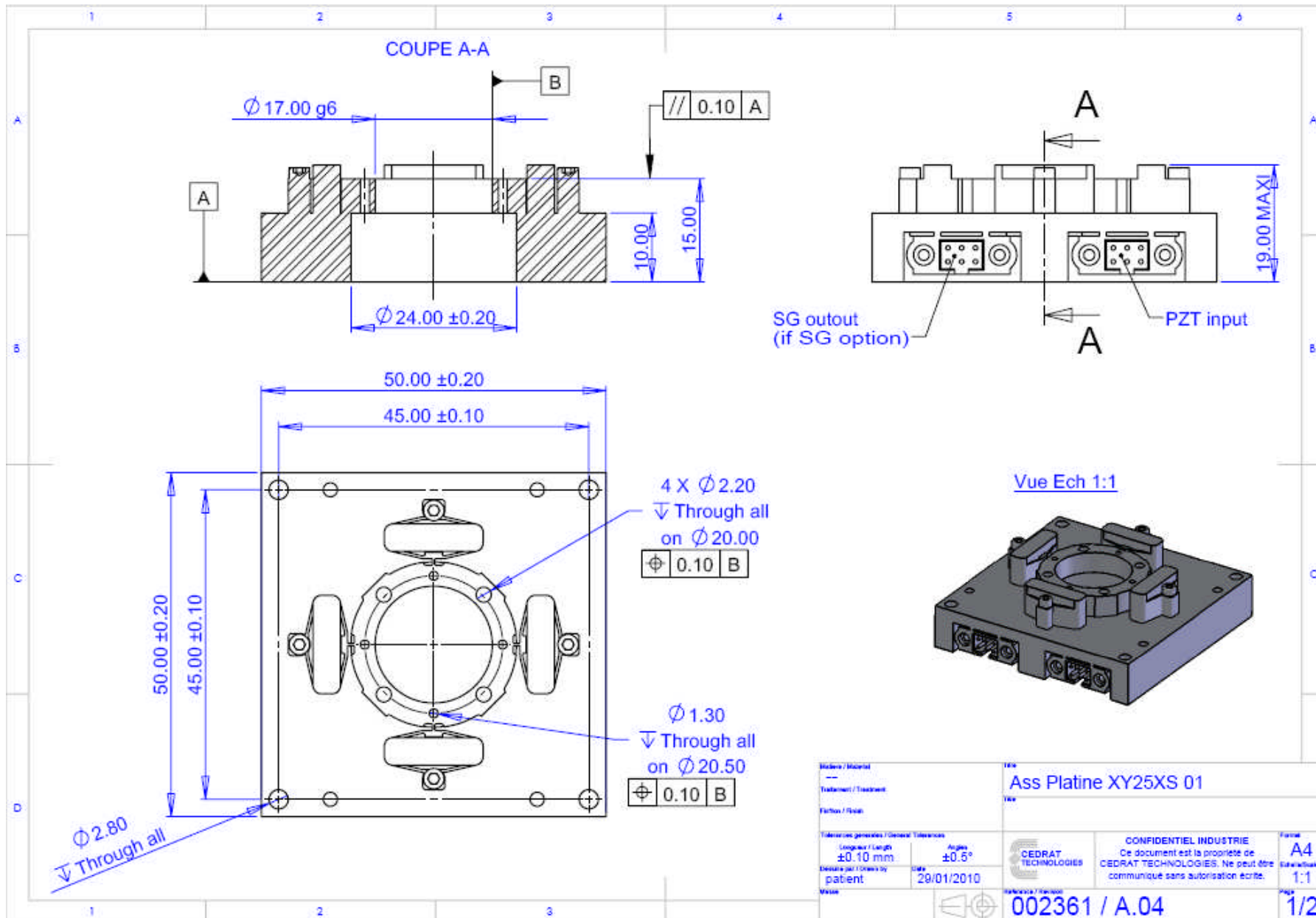

7 ANNEX 2: XY200M TECHNICAL CHARACTERISTICS

Table of standard properties of use and measurement

The properties defined in the table below, are set up according to the technical conditions of use and measurement. These properties are warranted within their variation range and in compliance with the standard technical conditions of use.

Properties XY200M	Standard technical conditions	Unit	Nominal values	Min. values	Max. values
Notes		-	-	-	-
Sensor options	SG, ECS	-	-	-	-
Mastered motions	TX, TY	-	-	-	-
Max. no load displacement	Quasistatic excitation, blocked-free	μm	200	180	230
Out of plane Z displacement		μm	1.00	0.60	1.40
Max. parasitic Z rotation		μrad	240.00	204.00	276.00
Max. parasitic XY rotation		μrad	50.00	42.50	57.50
Blocked force	Quasistatic excitation, blocked-free	N	118	94	142
Stiffness	Quasistatic excitation, blocked-free	N/ μm	0.59	0.47	0.65
Unloaded resonance frequency (in the actuation's direction)	Harmonic excitation, blocked-free, on the admittance curve	Hz	580	493	638
Unloaded response time	Quasistatic excitation, blocked-free	ms	0.86	0.78	0.99
Capacitance (per electrical port)	Quasistatic excitation, blocked-free, on the admittance curve	μF	6.30	5.67	8.19
Resolution		nm	2.00	-	-
Height		mm	22.00	21.90	22.10
Length		mm	100.00	99.90	100.10
Width		mm	100.00	99.90	100.10
Mass		g	180.0	-	-
Standard mechanical interface (payload)	3 \emptyset 2.7 mm holes on \square 38	-	-	-	-
Standard mechanical interface (frame)	4 \emptyset 4.5 mm holes on \square 84	-	-	-	-
Standard electrical interface	2 RG178B/U coaxial cables with Harwin connectors	-	-	-	-

Properties standard technical conditions of use and measurement

- Free-free** : The actuator is not fixed
- Blocked-free** : The actuator is fixed to a mechanical support assumed infinitely stiff
- Quasistatic excitation** : AC voltage between -20 and 150 V at 1 Hz
- Harmonic excitation** : Voltage of 0.5 V_{rms}, sinusoidal mode from 0 to 100 kHz
- Max. harmonic excitation** : Voltage defined by the measurement of max. displacement, sinus at resonance frequency
- Displacement measurement** : Laser interferometer, capacitive displacement sensor
- Admittance measurement** : HP 4194 A or Cypher C60 electrical impedance analyser
- Environment** : Ambient temperature (15-25°C) and dry air (Humidity < 50 % rH)

Any technical conditions of use, different from those defined above, can lead to temporary or definitive alterations of properties. Thank you to contact CEDRAT TECHNOLOGIES before using actuators under non standard technical conditions.

Factory tests carried out

- Test 1 : Electrical admittance vs. Frequency, free-free
- Test 2 : Displacement vs. input voltage

Extra factory tests

- Test 3 : Gain and linearity of the sensor
- Test 4 : Step response in closed loop
- Test 5 : Stability in closed loop

Mechanical interface

- | | | |
|--|---|---|
| <input type="checkbox"/> [FI] Flat Interface | <input type="checkbox"/> [H] Flat Interface with hole | <input type="checkbox"/> [TH] Flat Interface with threaded hole |
| <input type="checkbox"/> [SV] Specific version | <input type="checkbox"/> [FF] Free-free Interface | <input type="checkbox"/> [SI] Specific interface |

Available options

- | | | |
|---|--|--|
| <input type="checkbox"/> [SG] Strain gauges | <input type="checkbox"/> [ECS] Eddy Current Sensor | <input type="checkbox"/> [NM] Non-magnetic |
| <input type="checkbox"/> [VAC] Vacuum | <input type="checkbox"/> | |

8 ANNEX 3: XY200M INTERFACE

