

PIEZOELECTRIC OPTICAL MECHANISMS - PRODUCT AND WARRANTY INFORMATION

Version : 3.1.1

Date 16/03/06

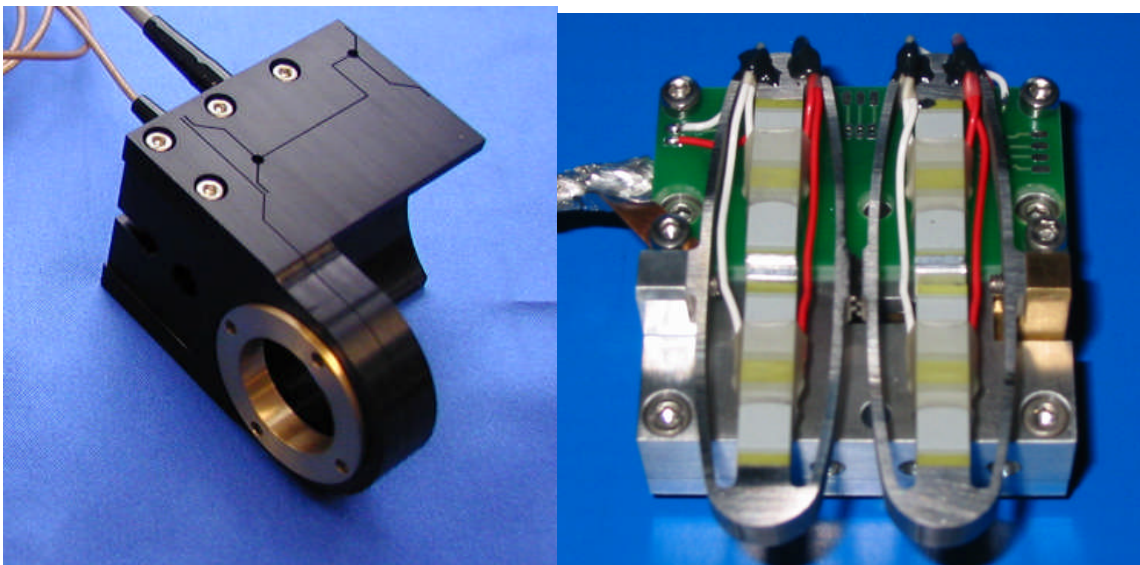

CAUTION: READ BEFORE OPENING

For safety purposes these instructions must be read before use of this product.

Piezoelectric products are not warranted against mechanical damage resulting from improper use, wherein excessive forces or voltages that are outside specified ranges are applied.

High voltage is present in this product.

Only qualified personnel should work on or around this equipment and only after becoming thoroughly familiar with all warnings, safety notices, and procedures contained herein.

The successful and safe operation of this equipment is dependent on proper handling, installation and operation.

A "qualified person" is one who is familiar with the installation, construction and operation of the equipment and the hazards involved. In addition, he/she has the following qualifications :

- is trained and authorized to energize, de-energize, clean, and ground equipment in accordance with established practices,
- is trained in the proper care and use of protective equipment in accordance with established safety practices.

TABLE OF CONTENTS

1	PRESENTATION	4
2	MOUNTING PROCEDURE	4
2.1	Mechanical mounting	4
2.2	Electrical connections.....	5
3	WARRANTY CONDITIONS AND EXCEPTIONS.....	6
4	INSPECTION UPON RECEIPT	6
	ANNEX 1 : OPP120SM TECHNICAL CHARACTERISTICS	7
	ANNEX 2 : FPS200M TECHNICAL CHARACTERISTICS.....	9
	ANNEX 3 : OPP120SM MECHANICAL INTERFACES	11
	ANNEX 4 : FPS200M MECHANICAL INTERFACE.....	13

1 PRESENTATION

The piezoelectric stage from CEDRAT TECHNOLOGIES SA are using multilayer actuators.

Piezoelectric Actuators must be handled carefully. Lifetime of Piezoelectric Multilayer actuators is not limited by wear. They can perform millions of cycles without loss of performance provided they are operated under suitable conditions.

The lifetime of a Piezoelectric Multilayer Actuators is a function of many combined parameters ; the most influencing being the applied voltage, the temperature and the humidity. For maximum lifetime, operating voltage should be minimized, especially when they are used in static conditions.

Tests have shown that the lifetime is reduced significantly, if the actuator is maintained continuously at the maximal operating voltage. For instance, a Piezoelectric Multilayer Actuator can be definitively damaged, if submitted to the maximal operating voltage (e.g. : high electrical field up to 1.5 kV/mm) during more than one hour.

A high self heating of the piezo ceramic may occur during a long use in dynamic (high frequency) operation. This can lead to depolarization or electrical breakdown of the piezo ceramic.

The mechanical installation or the induced moments under operation by the mechanism are the main sources of failure.

2 MOUNTING PROCEDURE

2.1 Mechanical mounting

Piezo mechanisms require a proper installation procedure :

- when mounting the payload onto the moving part of the piezo mechanism (see ANNEX 1 for the OPP120SM),
- when attaching the piezo mechanism to the baseplate.

In any case, please take care during the mounting procedure, to avoid excessive moments in the moving frame, when tightening the screws

2.2 Electrical connections

Electrical connectors are used for the stage driving, and in option position sensors.

During the mounting operation, electrical charges can be produced by the stage, through any applied force and the direct piezoelectric effect.

Before the electrical connection, please refer to the electrical connection scheme to avoid exchanging the driving and the sensing connectors.

The piezoelectric stage can be delivered with a full bridge of strain gauges (SG option) per axis. For these actuators, purchased without the sensing electronic, the connection between the strain gauges and the electronic must be realized with the customer : the electrical interface is described below :

The Strain Gauges used by CEDRAT TECHNOLOGIES display an Ohmic resistance of 350Ω for all the actuators and mechanisms.

For the strain gauges 350Ω the driving voltage ($V_{cc}-GND$) should not be higher than 10V.

The reduction of the driving voltage reduces the dissipated power and the related thermal effect, but also reduces the sensitivity of the bridge.

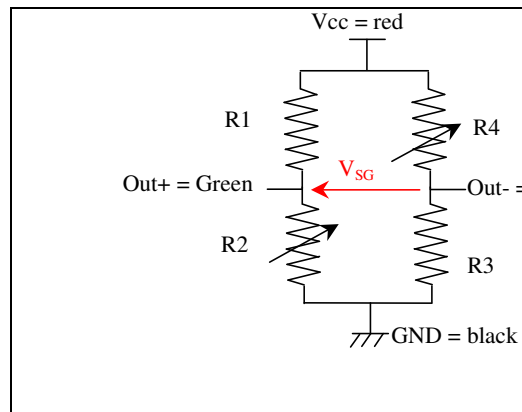

Figure 1 : Schematic of the Strain Gauges bridge

3 WARRANTY CONDITIONS AND EXCEPTIONS

The equipment is warranted for one year, including parts and labor, and only under standard technical conditions as outlined above and expressly mentioned in the technical data sheet. Repairs will be carried out at Cedrat Technologies or through your vendor.

Interventions or attempts to service or repair the Actuators by any unauthorized persons will invalidate this warranty.

In addition, this warranty will not apply if the APA is subjected to any of the following:

- improper handling, including, but not limited to, shocks and abrasions
- improper installation, including, but not limited to, excessive mechanical forces and moments, failure to use the standard electrical and mechanical interfaces
- excessive voltage, including, but not limited to, peak values outside the recommended operating range, DC values applied for excessive time periods
- inappropriate environmental conditions, including, but not limited to, high temperatures or high humidity
- attempt to modify the standard electrical connection of the APA (soldering out of electrical wires, plugs change,...) or the standard mechanical interfaces

4 INSPECTION UPON RECEIPT

This product has been inspected and shown to operate correctly at the time of shipment, as verified by the Factory Verification form that accompanies the actuator.

Immediately upon receipt of the product, it should be inspected carefully for any signs of damage that may have occurred during shipment. If any damage is found, a claim should be filed with the carrier.

The package should also be inspected for completeness according to the enclosed packing list. If an order is incorrect or incomplete, contact your distributor.

If a device requires service, please contact Cedrat Technologies or your local vendor. Please include the device model and serial number in all correspondence with Cedrat Technologies or your vendor.

ANNEX 1 : OPP120SM TECHNICAL CHARACTERISTICS

Table of standard properties of use and measurement

The properties defined in the table below, are set up according to the technical conditions of use and measurement. These properties are warranted within their variation range and in compliance with the standard technical conditions of use.

Properties OPP120SM	Standard technical conditions	Unit	Nominal values	Min. values	Max. values
Notes			-		
Sensors option			ECS		
Active axis			TZ		
Max. No-load displacement	Quasistatic excitation, blocked-free	μm	140	119	161
Max. parasitic X Y rotations	Quasistatic excitation, blocked-free	μrad	25	12,50	37,50
Voltage range		V	-20 ... 150		
Resolution		nm	14	-	-
Stiffness		N/ μm	0,71	0,6	0,9
Height		mm	50	49,0	50,5
Dimensions		mm	65 * 40	-	-
Mass		g	180	-	-
Unloaded resonance frequency (in the actuation's direction)	Harmonic excitation, blocked-free, on the admittance curve	Hz	600	510	720
Response time		ms	0,83	0,71	0,96
Loaded resonance frequency (in the actuation's direction) load = 50 g		Hz	440	374	506
Loaded response time load = 50 g		ms	1,1	0,97	1,31
Capacitance (per electrical port)	Quasistatic excitation, blocked-free	μF	3,15	2,84	4,10
Mechanical interfaces (payload)	objective interface max M25*0.75 (to be specified)				
Mechanical interfaces (frame)	microscope interface (max M25*0.75) to be specified				
Electrical interfaces	1 RG178B/U coaxial cable				

Properties standard technical conditions of use and measurement

- Free-free** : The actuator is not fixed
- Blocked-free** : The actuator is fixed to a mechanical support assumed infinitely stiff
- Quasistatic excitation** : AC voltage between -20 and 150 V at 1 Hz
- Harmonic excitation** : Voltage of 0.5 V_{rms}, sinusoidal mode from 0 to 100 kHz
- Max. harmonic excitation** : Voltage defined by the measurement of max. displacement, sinus at resonance frequency
- Displacement measurement** : Laser interferometer, capacitive displacement sensor
- Admittance measurement** : HP 4194 A electrical impedance analyser
- Environment** : Ambient temperature (15-25°C) and dry air (Humidity < 50 % rH)

Any technical conditions of use, different from those defined above, can lead to temporary or definitive alterations of properties. Thank you to contact CEDRAT TECHNOLOGIES before using actuators under non standard technical conditions.

Factory tests carried out

- Test 1 : Electrical admittance vs. Frequency, free-free
- Test 2 : Displacement vs. input voltage

Extra factory tests

- Test 3 : Gain and linearity of the sensor
- Test 4 : Step response in closed loop
- Test 5 : Stability in closed loop

Mechanical interface

- | | | |
|--|---|---|
| <input type="checkbox"/> [FI] Flat Interface | <input type="checkbox"/> [H] Flat Interface with hole | <input type="checkbox"/> [TH] Flat Interface with threaded hole |
| <input type="checkbox"/> [SV] Specific version | <input type="checkbox"/> [FF] Free-free Interface | <input type="checkbox"/> [SI] Specific interface |

Available options

- | | | |
|--|---|--|
| <input checked="" type="checkbox"/> [SG] Strain gauges | <input type="checkbox"/> [CS] Capacitive displacement sensor | <input type="checkbox"/> [NM] Non-magnetic displacement sensor |
| <input checked="" type="checkbox"/> [VAC] Vacuum | <input checked="" type="checkbox"/> [ECS] Eddy Current Sensor | |

ANNEX 2 : FPS200M TECHNICAL CHARACTERISTICS

Table of standard properties of use and measurement

The properties defined in the table below, are set up according to the technical conditions of use and measurement. These properties are warranted within their variation range and in compliance with the standard technical conditions of use.

Properties FPS200M	Standard technical conditions	Unit	Nominal values	Min. values	Max. values
Notes			-	-	-
Sensors option			SG	-	-
Active axis	TZ		-	-	-
Max. No-load displacement	Quasistatic excitation, blocked-free	μm	400	360	460
Stiffness	Quasistatic excitation, blocked-free	N/μm	3,17	2,54	3,49
Height	Quasistatic excitation, blocked-free	mm	18,50	18,30	18,70
Dimensions		mm	60 * 44	-	-
Mass		g	300,0	285,0	315,0
Unloaded resonance frequency (in the actuation's direction)	Harmonic excitation, blocked-free, on the admittance curve	Hz	900	810	1035
Response time	Quasistatic excitation, blocked-free	ms	0,56	0,50	0,64
Capacitance (per electrical port)	Quasistatic excitation, blocked-free	μF	3,15	2,84	4,10
Mechanical interfaces (payload)			4 slits (width 0.6 mm)	-	-
Mechanical interfaces (frame)			4 holes Ø 3mm on [] 24*38 mm	-	-
Electrical interfaces			2 RG178B/U coaxial cables	-	-

Properties standard technical conditions of use and measurement

- Free-free** : The actuator is not fixed
- Blocked-free** : The actuator is fixed to a mechanical support assumed infinitely stiff
- Quasistatic excitation** : AC voltage between -20 and 150 V at 1 Hz
- Harmonic excitation** : Voltage of 0.5 V_{rms}, sinusoidal mode from 0 to 100 kHz
- Max. harmonic excitation** : Voltage defined by the measurement of max. displacement, sinus at resonance frequency
- Displacement measurement** : Laser interferometer, capacitive displacement sensor
- Admittance measurement** : HP 4194 A electrical impedance analyser
- Environment** : Ambient temperature (15-25°C) and dry air (Humidity < 50 % rH)

Any technical conditions of use, different from those defined above, can lead to temporary or definitive alterations of properties. Thank you to contact CEDRAT TECHNOLOGIES before using actuators under non standard technical conditions.

Factory tests carried out

- Test 1 : Electrical admittance vs. Frequency, free-free
- Test 2 : Displacement vs. input voltage

Extra factory tests

- Test 3 : Gain and linearity of the sensor
- Test 4 : Step response in closed loop
- Test 5 : Stability in closed loop

Mechanical interface

- | | | |
|--|---|---|
| <input type="checkbox"/> [FI] Flat Interface | <input type="checkbox"/> [H] Flat Interface with hole | <input type="checkbox"/> [TH] Flat Interface with threaded hole |
| <input type="checkbox"/> [SV] Specific version | <input type="checkbox"/> [FF] Free-free Interface | <input type="checkbox"/> [SI] Specific interface |

Available options

- | | | |
|--|--|--|
| <input checked="" type="checkbox"/> [SG] Strain gauges | <input type="checkbox"/> [CS] Capacitive displacement sensor | <input type="checkbox"/> [NM] Non-magnetic displacement sensor |
| <input checked="" type="checkbox"/> [VAC] Vacuum | <input type="checkbox"/> [ECS] Eddy Current Sensor | |

ANNEX 3 : OPP120SM MECHANICAL INTERFACES

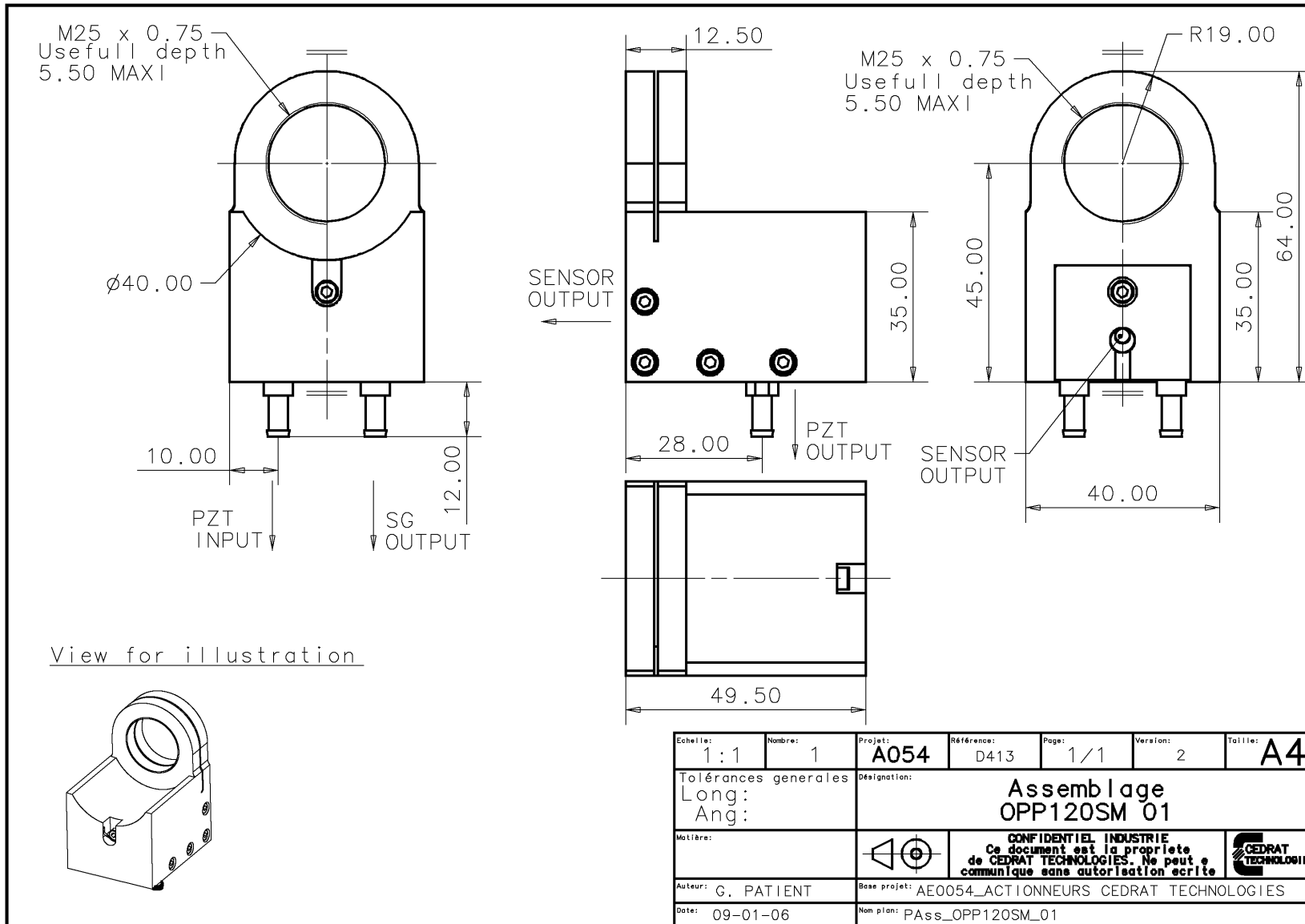

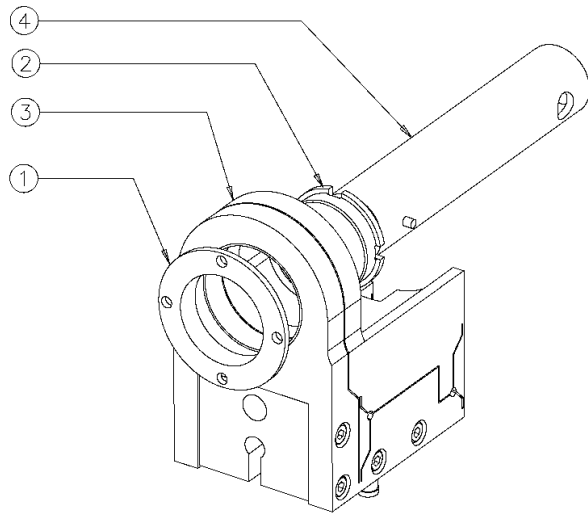

4	1	Ass Outillage Montage	1	
3	1	Ass OPP120SM 01	10	
2	1	Adaptateur Serrage Male 20.25 RMS	1	
1	1	Adaptateur de Serrage Male M25x0.75	1	
N°NbrDesignation			VerMateriau	

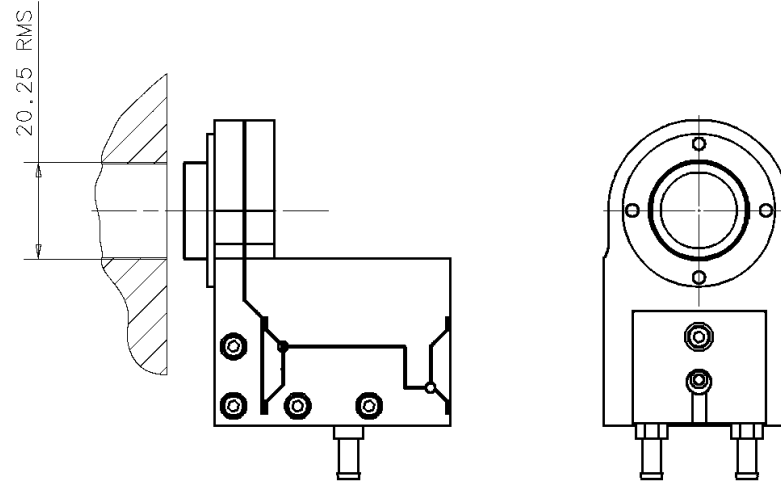

Notice of use :

- A / Screw the ring ① on OPP120SM
- B / Place the OPP120SM on microcope barrel and insert the ring ②.
- C / Tighten the ring by hand
- D / Finish the tightening with the mouting tool.

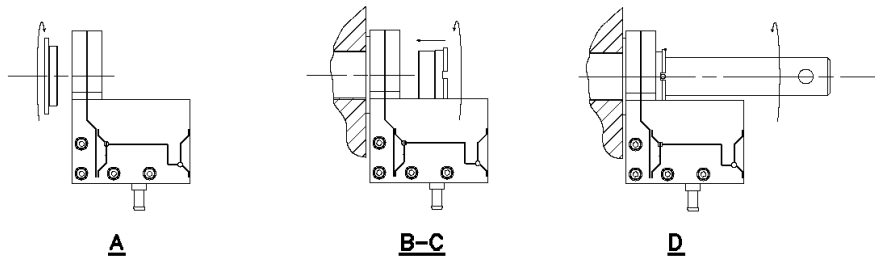

Echelle: 1:1	Nombre: 1	Projet: AR0403	Reference: D018	Page: 1/1	Version: 1	Taille: A3
Tolérances générales Long: Ang:		Designation: Notice of Fitting OPP120SM On Microscope Barrel 20.25 RMS				
Métré:					CONFIDENTIEL INDUSTRIE Ce document est la propriété de CEDRAT TECHNOLOGIES. Ne peut être communiqué sans autorisation écrite.	
Auteur: G. PATIENT		Base projet: AR0403_MECANI_SME_X				
Date: 23-02-06		Nom plan: Ass OPP120SM + Bague 20.25 RMS				

ANNEX 4 : FPS200M MECHANICAL INTERFACE

