

The BRUCE Hold-Down & Release Mechanism (HDRM) is a space qualified pin puller electromagnetic actuator, developed by CEDRAT TECHNOLOGIES under CNES contract (French National Space Agency).

The BRUCE HDRM has been specifically developed for Space applications requiring locking of moving parts during the launch phase, in order to sustain vibration and shock loads, with an unlocking feature once in flight by means of a very short electrical pulse. Its locking feature is reversible on ground, by the use of an appropriate tooling, and is one shot in flight.



The key features of the BRUCE HDRM, compared to other alternate existing solutions, are listed here under:

- Actuation compatible with pyrotechnic cords electrical commands (warranted unlocking <10ms)
- Low power electrical actuation
- No debris generation during actuation
- High actuation cycling capabilities (reversible on ground with appropriate locking tooling)
- Unlocking time and power insensitive to temperature in the range [-150 °C to 150 °C]
- Low level shock generation during actuation
- Electrical impedance adjustable to the different possible flight Bus voltages
- Compatible with vacuum and low outgassing requirements
- Designed and manufactured according to ECSS standards
- Synchronised actuation of multiple BRUCE configurations
- No magnetic moment
- ITAR free

FLIGHT MODEL HERITAGE

The BRUCE 25N HDRM has been developed in the frame of the TARANIS project:

- 2 Engineering models
- 2 Qualification models
- 3 Flight models

ACCEPTANCE TESTS AND COMMISSIONING AT MANUFACTURING

The acceptance tests are defined in accordance with the specific space programs requirements, and are proposed here under as possible suggestions:

Mechanical acceptance tests

- Sine and random vibration tests
- SRS Shock tests

Functional unlocking acceptance tests (*)

- Tests at ambient temperature
- Tests at defined extreme operational temperatures, typically -150 °C and 150 °C

- Tests with thermal cycling

(*) The functional unlocking tests can be performed under specific operational conditions on demand:

- Tests can be performed in vacuum conditions
- Tests can be performed with the bus voltage defined for the application, and with an electrical impedance adaptation if necessary (coil wire diameter and length adjustment)

Specific commissioning procedure on demand

- Bake out according to application requirements

TABLE OF QUALIFIED PROPERTIES FROM TARANIS SPACE PROJECT

The properties defined in the table below, have been qualified according to ECSS standards for the requirement of the TARANIS project.

PROPERTIES	BRUCE 25N QUALIFIED VALUES	UNIT
Length	56,6	mm
Body diameter	24,6	mm
Diameter (including fastening holes)	31,75	mm
Stroke	6,6	mm
Weight	120	g
Pull-off strength without radial force	>25 (*)	N
Max axial load in locked state	390	N
Max axial load during unlocking	20 (*)	N
Max radial load in locked state	420	N
Max radial load during unlocking	15 (*)	N
In service temperature	-150 / +150	°C
Storage temperature	-160/ +160	°C
Actuator resistance at 20 °C	1,9	Ohm
Operational current	8	A
Unlocking time	<10	ms
Life time	1 cycle in orbit, >10 on ground	Cycles
Actuation redundancy	No	-
Vacuum achieved during operational tests	1e-7	mbar
Thermal cycling -160°C/+160°C	8	Cycles

Table 1: (*) 100N pulling force implemented, and derated to 25N w.r.t ECSS design safety factors.

MECHANICAL TESTS LEVELS QUALIFIED FROM TARANIS SPACE PROJECT

MECHANICAL TESTS	BRUCE 25N QUALIFIED VALUES
Random vibration	1g ² /hz [100Hz-400Hz], 2,5min per axis, 30grms
Sine Sweep vibration	20g [20Hz-100Hz], 2oct/min
SRS Shock	20g/100Hz, 1000g/1000Hz, 1000g/10000Hz

INTERFACES (BRUCE 25N)

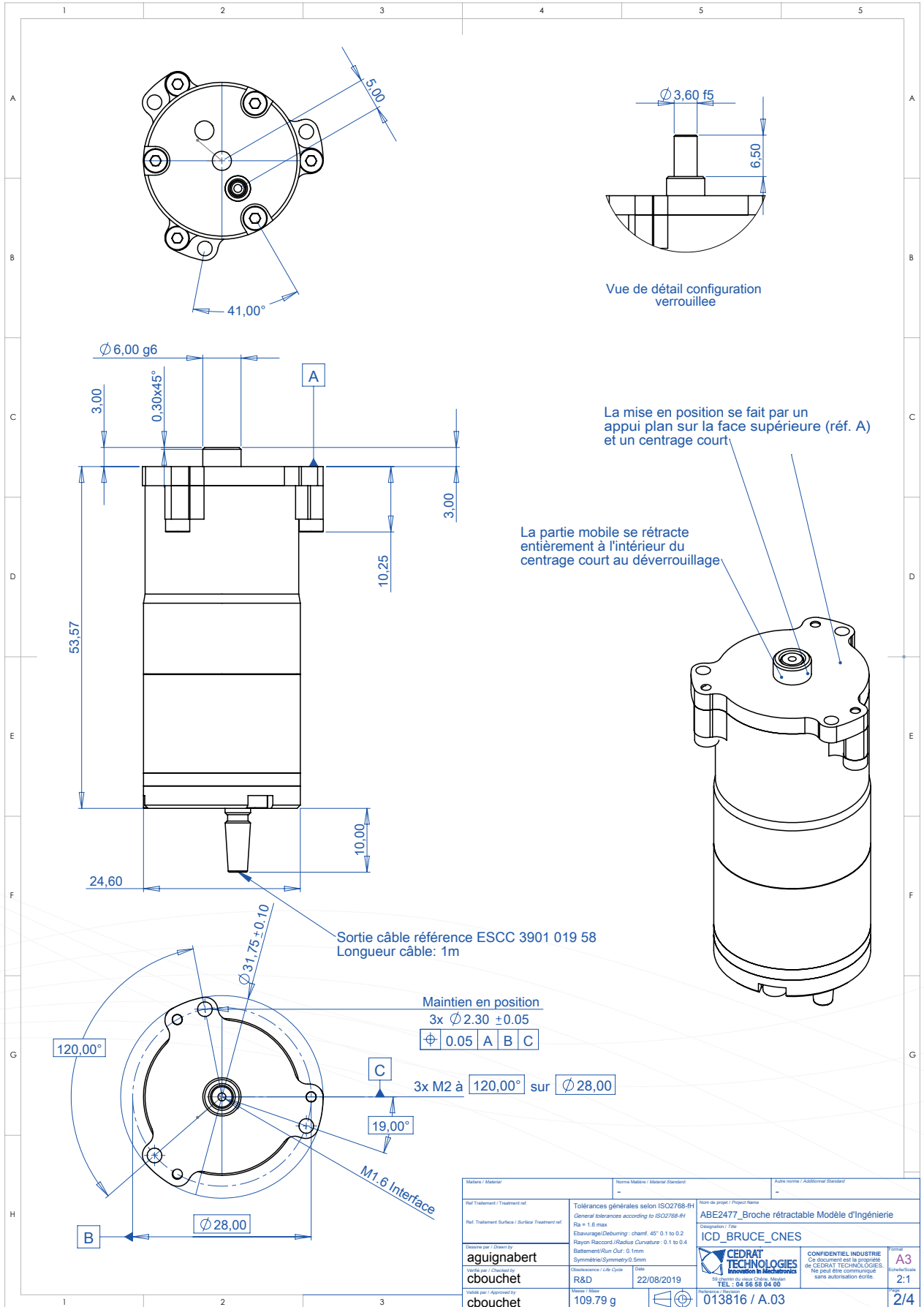

Matière / Material		Normes Matériau / Material Standard		Autre norme / Additional Standard	
Ref. Traitement / Treatment ref.		Tolérances générales selon ISO2768-M		Nom de projet / Project Name	
Ref. Traitement Surface / Surface Treatment ref.		General tolerances according to ISO2768-M		ABE2477_Broche rétractable Modèle d'ingénierie	
Designé par / Drawn by		Elavorage/Deburring: chamf. 45° 0.1 to 0.2		Designation / Title	
aguihabert		Rayon Raaccori/Radiuse Curvature: 0.1 to 0.4		ICD_BRUCE_CNES	
Vérifié par / Checked by		Battement/Run Out: 0.1mm			
cbouchet		Symétrie/Symmetry: 0.5mm		<p>CONFIDENTIEL INDUSTRIE Ce document est la propriété de CEDRAT TECHNOLOGIES. Ne peut être communiqué sans autorisation écrite.</p>	
Validé par / Approved by		Classification / Life Cycle		Formet	
cbouchet		R&D		A3	
		Date		Echelle/Scale	
		22/08/2019		2:1	
		Masses / Masses		Niveau / Level	
		109.79 g		2/4	
				013816 / A.03	